



**WARNING:**

Validate the kit contents with the component list included on this page before proceeding. This kit is intended to be used in a modified vehicle. Please read this page thoroughly and be sure that you understand everything explained on it prior to opening any of the enclosed packages, or before attempting to install any of the components. Once this kit has been opened or a component installed, the kit is not returnable.

1. This kit **IS NOT** set up with a resistance wire for a standard points-type ignition system. It is wired with a full 12-volt primary ignition feed. See pages 20 through 22 for the various Ignition System Wiring configurations.
2. This kit includes the wiring to support the use of a factory heater system and/or aftermarket heater and A/C systems. This kit also includes the main power feed and the compressor extension wires that will support the use of the factory original **A/C** system, but **DOES NOT** include any of the other factory A/C wiring.
3. This kit only supports the use of a higher current, self-exciting 1-wire alternator or GM SI type internally regulated alternator. Optional adapters may be necessary for certain applications.
4. AAW **DOES NOT** support the use of the factory ammeter. We recommend the use of a voltmeter to monitor your charging system.

510838 - Classic Update Series Kit  
1971-80 IH Scout

This kit contains the following components:

Bag	Part Number	Description	Quantity
G	510839	Dash Harness kit	1
H	510840	Instrument Cluster wiring kit	1
J	510841	Engine Wiring Kit	1
L	510842	Front Light wiring kit	1
M	510843	Rear Body Wiring kit	1
	510867	Fuse, Relay, and Flasher kit	1
	510476	Alternator and Main Power Conn. kit	1
	510730	VSS Lead Wires	1
	500919	Practice Terminal Crimping set	1
	500042	Dimmer Switch	1
	500332	Headlight Switch	1
	92973232	Firewall Mod Template	1

Validate the kit contents with this component list. If there are any discrepancies with incorrect or missing parts, stop your installation and notify the supplier you purchased the kit from before proceeding.

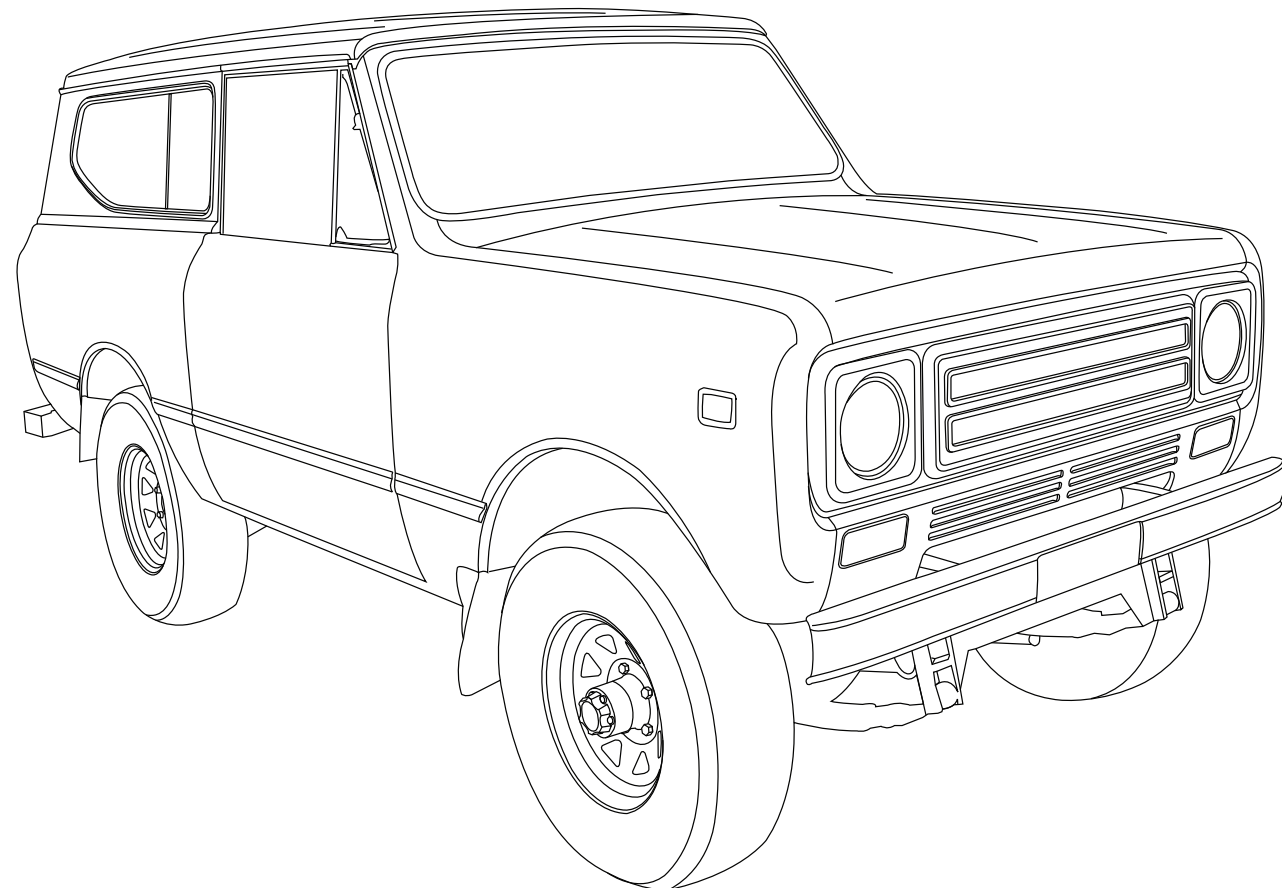

**510838 1971-80 IH Scout**  
**Instructions**  
*Classic Update Series*



**American  
Autowire**

© COPYRIGHT 2004 American Autowire / Factory-Fit  
Used with express permission of  
American Autowire / Factory-Fit

# START HERE !

## PLEASE READ THIS BEFORE STARTING INSTALLATION !

This wiring kit is designed for ease of installation. Please read the guidelines below BEFORE STARTING installation to guarantee a successful job. Use an appropriate crimping tool, which folds the wings of the open barrel terminals down into the wire, as shown on this page. If you use our crimping tools and correctly crimp the included terminals, soldering is not necessary. If you are unsure about a particular crimp, soldering is recommended. Our factory crimped terminations are installed by GM approved five ton presses, and soldering these terminations is not necessary.



AAW offers a great terminal crimping video entitled "Proper Crimping Video". It can be viewed by visiting YouTube.

Type the following address into your web browser, to go directly to the video:  
[www.youtube.com/watch?v=JAgEDoVI-co](http://www.youtube.com/watch?v=JAgEDoVI-co)

Youtube Channel:  
[www.youtube.com/user/WiringHarness](http://www.youtube.com/user/WiringHarness)



If you have any questions concerning this or any of our products, please feel free to call us at 1-856-933-0801.

We carry many accessories for your 1971-80 Scout:



37796 SI to CS  
Alternator Adapter



500479 40 Amp  
electric fan relay



510226 LED  
Electronic flasher

The terminals that we supply in our kits, utilize what is known as an F crimp. The F crimp, in a cross section, will look like the illustration below, when done correctly.

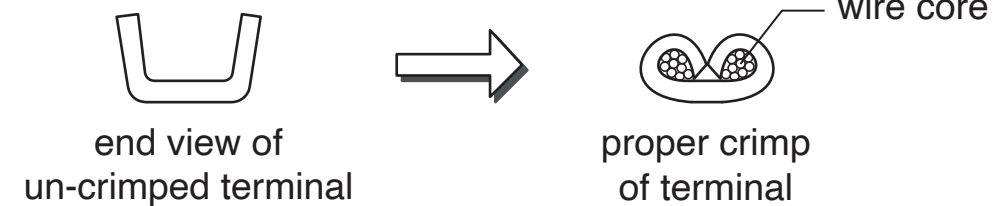

We carry the following crimping hand tools, to help with your terminal crimping. These hand tools are available, for purchase or rental.

p/n 510585  
OEM small gauge terminal  
crimping tool



p/n 510586  
OEM large gauge terminal and double  
small gauge terminal crimping tool

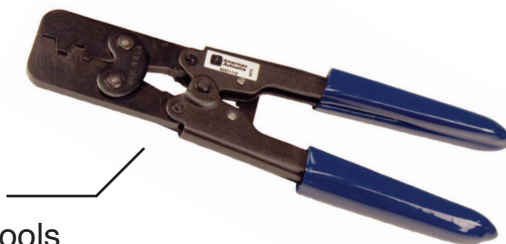

p/n 510587  
Includes Both  
terminal crimping tools

## Table of Contents:

**Bags: Pages: Sections:**

	4-5	<b><u>Fuse, Circuit Breaker, Relay and Flasher (510867) Placement, and Fuseblock/Bulkhead installation</u></b>		
G	6-14	<b><u>Dash Harness (510839) (Installation)</u></b> – This is the main harness in the kit and it should be installed first. It can be installed directly into the original, or modified, firewall opening and routed behind the dash frame with the frame just as your original was. This harness connects to:		
		Accessory Power Feed connector	Cluster Connection for Temp. and Oil Gauges	Neutral Safety Switch Relay
		Park Brake Switch	Cluster Connection for Gas Gauge	Radio
		Third Brake Light Feed	Hazard Flasher	Clock Feed
		LH & RH Courtesy Lights	Ignition Switch	Fog Lamp Switch
		Horn Relay	Turn Signal Switch	Dash Grounds
		Fog Lamp Relays	Electric Speedo Ground	Blower Motor
		Headlamp Dimmer Switch	Dash Light Candelabra (optional lamp use)	Wiper Motor
		Stop Light Switch	Heater Panel Light	Electric Speedometer Extension
		Interior 12V and tach leads for ECU (if equipped)	Heater/Blower Motor Switch	12V Fused Battery Feed for Console
		Headlight Switch	Cigar Lighter	4WD Indicator Lamp and 4WD Switch
		Wiper Switch	Speedo Cluster Connection	Illumination Lamp Feed for Console
		Factory A/C Feed	Electric Speedometer Connection	Back Up and Neutral Safety Switch Connections
		A/C Compressor Feed	Fuel Pump Lead	
H	15-18	<b><u>Gauge Cluster Harness (510840)</u></b> – This harness is assembled by the customer and connects to:		
		Printed Circuit Boards (PCB)	Dash Harness	
	18	<b><u>Aftermarket Gauges:</u></b>		
		All gauges (Volts, Fuel, Speedo, Oil, Temp, Tach)		
J	19-23	<b><u>Engine Harness (510841)</u></b> – This harness connects to the Dash harness and the:		
		SI Alternator Connections	Ignition System	Tachometer Signal
		Electric Choke	Starter Solenoid	Oil Pressure Sender
		The Assembled Mega Fuses	Engine Temperature Sender	A/C Compressor Lead
				Fuel Pump Lead
L	24-25	<b><u>Front Light Harness (510842)</u></b> - This harness connects to the Dash harness and the:		
		LH & RH Headlights	LH & RH Side Markers	Fog Lamps
		LH & RH Parking/Turn Lamps	Washer Pump/Reservoir	Horns
		Brake Warning Switch	Electric Fan Trigger Feed	
M	26-29	<b><u>Rear Body Harness (510843)</u></b> – Interior and exterior connections. This harness connects to the Dash harness and the:		
		B/U, Stop/Tail, Rear Running Lamp Leads	71-77 Side Marker extensions	Dome Light Wires
		Tail Lamp Connections and Grounds	Fuel Tank Lead	
		78-80 Tail Light Extensions (Stop/Tail, B/U, Side Mkr.)	Fuel Tank Sender and Ground Extension	



www.americanautowire.com 856-933-0801

**1971-80 IH Scout**  
**510838**

*Classic Update Series*

92973231 Rev 1.0 10/14/2024

# Fuse Block and Bulkhead installation instructions:

**NOTE:** Prior to installing the Dash harness into the vehicle, obtain the Fuse, Flasher, and Relay Kit, **510867**, and plug all of the fuses and turn signal flasher into the Fuse Block (see below). Also, plug the Horn Relay and Fog Lamp Relays into the relay bases, and the hazard flasher into its connector (see page 7) on the dash harness.

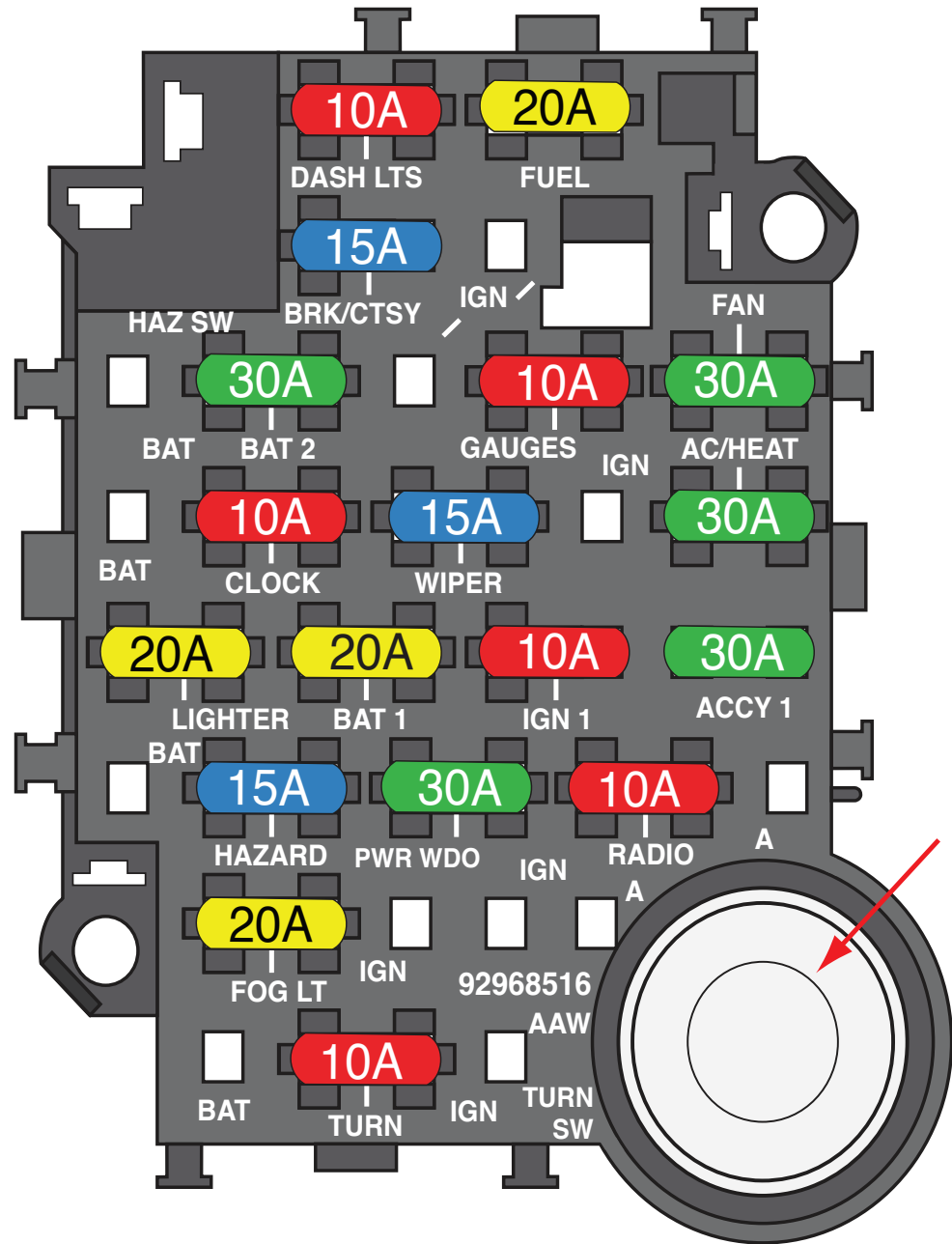

Assembled fuse block with fuses and flashers installed.



**American  
Autowire**

www.americanautowire.com 856-933-0801

Fuse usage details. **NOTE:** Head lights are protected by the H/L switch internal 25A breaker

Fuse #	Fuse Block Printing	Fuse Rating	System Wiring Protected
1	DASH LTS	10A	Cluster lights, Tachometer lights, Speedometer lights, Heater Control Panel Light, Optional dash lights plugged into candelabra
2	FUEL	20A	Electric fuel pump, Ignition feed for electric speedo (Accy 6-way conn).
3	BRK/CTSY	15A	Stop and third brake lights, under dash courtesy lights, dome light, hood light, Fog light relay coil, Rear running lights, Front park lights.
4	BAT 2	30A	B+ Feed for any optional battery powered feed. (Accy 6-way conn)
5	GAUGES	10A	Gauges (Temp, Fuel, Oil Pressure and Voltmeter). B+ for options as tachometer 4x4 Light, Back-up Lights, Brake Warning Light
6	FAN	30A	Electric fan
7	CLOCK	10A	Battery feed for clock, radio battery feed
8	WIPER	15A	Wiper motor, Front windshield washer pump
9	AC/HEAT	30A	Main Heater or A/C Feed Switch
10	LIGHTER	20A	Cigar Lighter, Option battery fused feed to console area.
11	BAT 1	20A	B+ Feed for any optional battery powered feed. (Accy 6-way conn)
12	IGN 1	10A	Electric choke
13	ACCY 1	30A	Feed for any optional accessory powered feed. (Accy 6-way conn).
14	HAZARD	15A	Hazard lights
15	PWR WDO	30A	Ignition Feed for options such as power windows (Accy 6-way connector)
16	RADIO	10A	Accessory feed "on-off" for the radio
17	FOG LT	20A	Fog lamp feed
18	TURN	10A	Turn signal

Turn  
flasher  
from  
510867

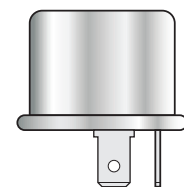

Hazard  
flasher  
from  
510867

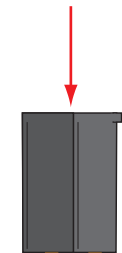

Hazard flasher  
connector from  
page 7

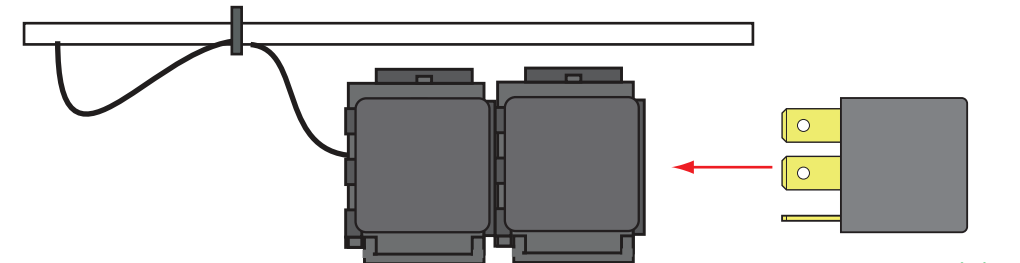

#1 #2  
Fog light bases and relays from page 7  
(both of these must be plugged in for  
your fog lamps to operate)

5-pin relays (2)  
from 510867

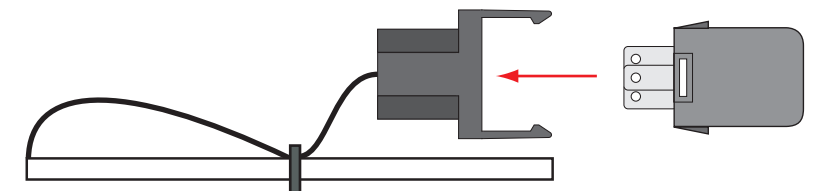

Horn relay connector  
and relay from page 7

3-pin relay  
from 510867

**1971-80 IH Scout  
510838**

*Classic Update Series*

92973231 Rev 1.0 10/14/2024

## Fuse Block and Bulkhead installation instructions:

### **STEP 1: DISCONNECT YOUR BATTERY**

Disconnect the battery before installing the wiring kit. This is to prevent any accidental shorting caused by bare wire ends.

### **STEP 2: LOAD THE FUSE BLOCK**

Prior to installing the dash harness to the dash, obtain the Fuse, Flasher, and Relay Kit **510867** and plug all of the fuses and turn signal flasher into the fuse block. Also, plug the horn relay, fog lamp relays, and hazard flasher into the dash harness. (See page 4)

### **STEP 3: PREPARING TO INSTALL THE DASH HARNESS**

The Dash Harness routing will be the same as the original factory Instrument Panel Wiring Harness routing. Be sure to duplicate this routing.

### **STEP 4: START INSTALLING THE KIT**

This kit is divided into individual sections that are identified by a letter printed on the sheets enclosed in each bag. The items covered, the order of installation, and the pages with their detailed installation instructions are shown on page 3.

### **Fuse Block and Bulkhead Attachment**

Locate the original factory fuse block/bulkhead opening in the upper LH corner of the firewall from the inside (From the outside, upper RH corner). If your truck is a 78 to 80 model, no modification is required as the fusebox and bulkhead will install directly in the factory firewall opening. If your truck is a 71-77 model, it will be necessary to use the 92973232 Template included in this kit to modify the opening in your firewall, and to drill two new mounting holes. Attach the fuse block and bulkhead assembly to the firewall using the self tapping screws "L" found on page 6.

(See figure A below for details)

## INSTALLING THE FUSE BLOCK AND BULKHEAD ASSEMBLY

### FIGURE "A"

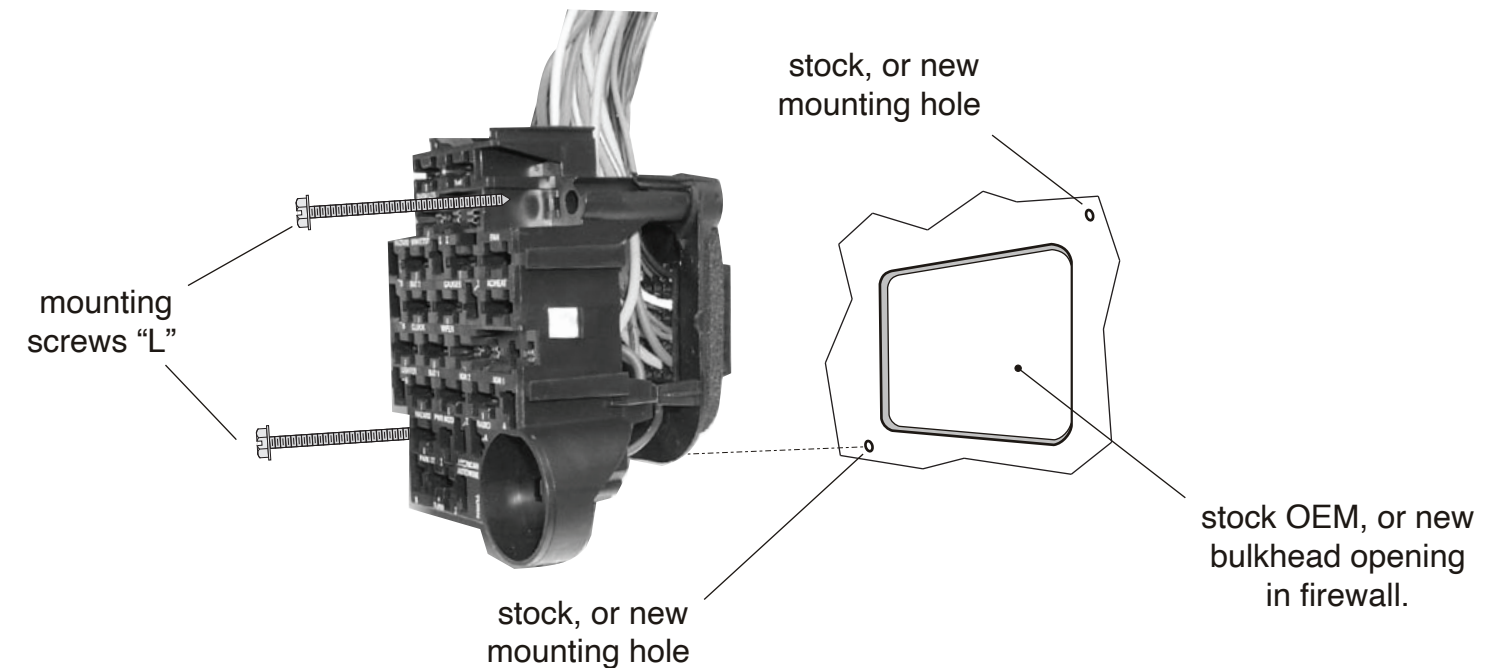

www.americanautowire.com 856-933-0801

**1971-80 IH Scout**  
**510838**

*Classic Update Series*

92973231 Rev 1.0 10/14/2024

# 510839 Dash/Main harness installation instructions:

Below are the supplied misc. terminals, connector bodies and assorted components included in the 510839 Dash Harness and Loose Piece bags. These will be used to complete your Dash Harness connections and are referred by the letters and descriptions below from this point forward.

**A**  (LH Courtesy Light Jumper Harness, 1 pc)

**B**  (RH Courtesy Light Jumper Harness (longer), 1 pc)

**C**  (Console Illumination Jumper Harness, 2 pcs)

**D**  ( Back Up Jumper Harness, 1 pc)

**E**  (Neutral Safety Jumper Wire, Manual Trans, 1 pc)

**F**  (12V Fused Battery Feed Console Jumper Wire, 1 pc)

**G**  (4WD Indicator Lamp Jumper Wire, 1 pc)

**H**  (Third Brake Light Jumper Wire, 1 pc)

**J**  (Neutral Safety Jumper Wire, Automatic Trans, 1 pc)

**K**  (Fuel Pump Jumper Wire, 1 pc)

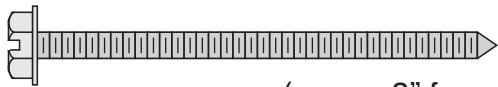
**L**  (screw, 3", fuse box, 2 pcs.)

**M**  (56 series double female terminal, 5 pcs)

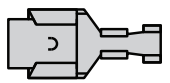
**N**  (56 series single female terminal, 8 pcs)

**P**  (Large male bullet terminal, 4 pcs)

**Q**  (small rubber sleeve, 3 pcs)

**R**  (Pack-Con male terminal, 10 pcs)

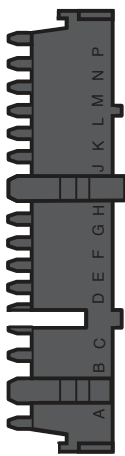
**S**  (Turn Signal Switch, Pack-Con 14-way male connector, 1 pc)

**T**  (56 series single female connector, 1 pc)

**U**  (56 series single male connector, 3 pc)

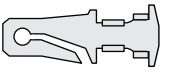
**V**  (56 series small gauge male terminal, 5 pcs.)

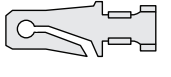
**W**  (56 series large gauge male terminal, 2 pcs.)

**X**  (Female pin terminal, 3 pcs)

**Y**  (large rubber sleeve, 2 pcs)



www.americanautowire.com 856-933-0801

**1971-80 IH Scout**  
**510838**

*Classic Update Series*

92973231 Rev 1.0 10/14/2024

# 510839 Dash/Main harness installation instructions:

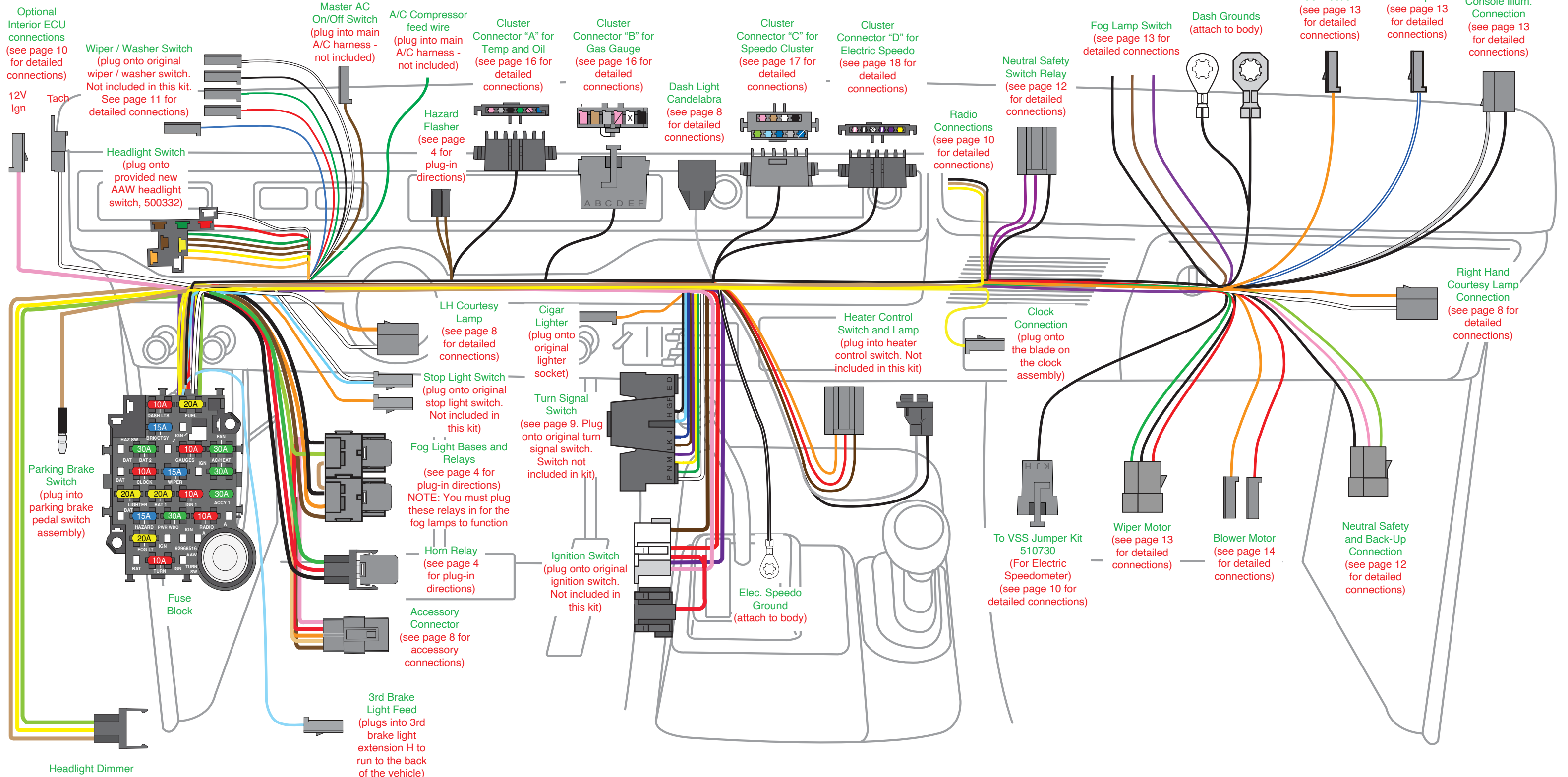

**1971-80 IH Scout**  
**510838**  
*Classic Update Series*

92973231 Rev 1.0 10/14/2024

# 510839 Dash/Main harness installation instructions:

## Underdash courtesy lamp and doorjamb switch instructions:

**All applications:** Plug the LH and RH courtesy lamp connections from the dash harness into the two loose courtesy lamp extensions, items "A" and "B" from page 6. Install the completed courtesy lamps in the stock locations.

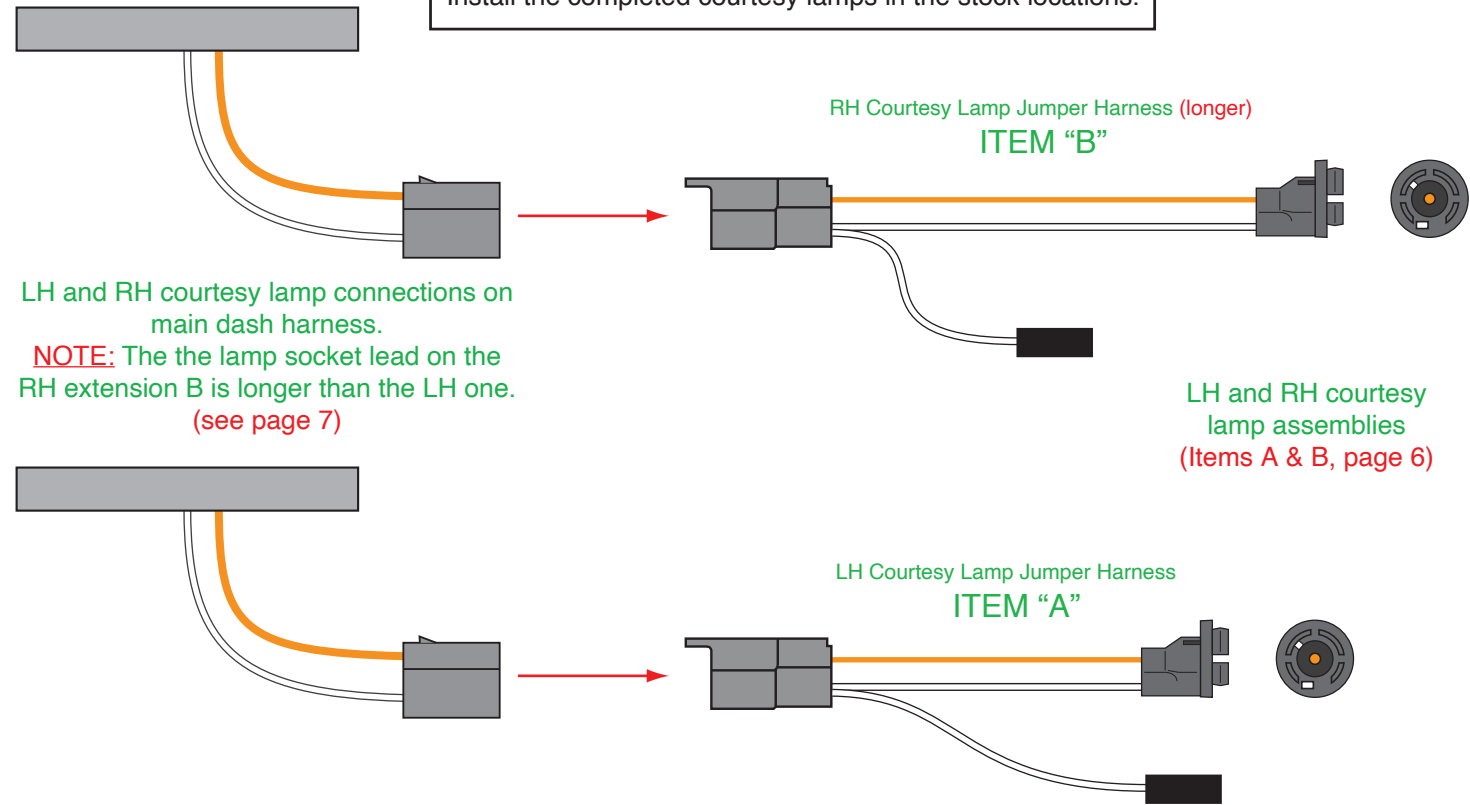

## Accessory dash light candelabra instructions:

**All applications:** We have provided an accessory dash light candelabra on the dash harness (see page 7) that can be used to add additional dash illumination lights to things like underdash gauges, radio lamp, etc. We have also provided loose piece terminals "P" and sleeves "Q" in the dash loose piece parts kit, 92973236, that can be applied to your wires. Simply slide the sleeve "Q" onto your wire, crimp terminal "P" onto the wire, then slide sleeve "Q" up over the crimped area of terminal "P". Once complete, plug the male bullet terminals directly into the candelabra to complete your accessory lighting circuits. See the illustration at right for details.

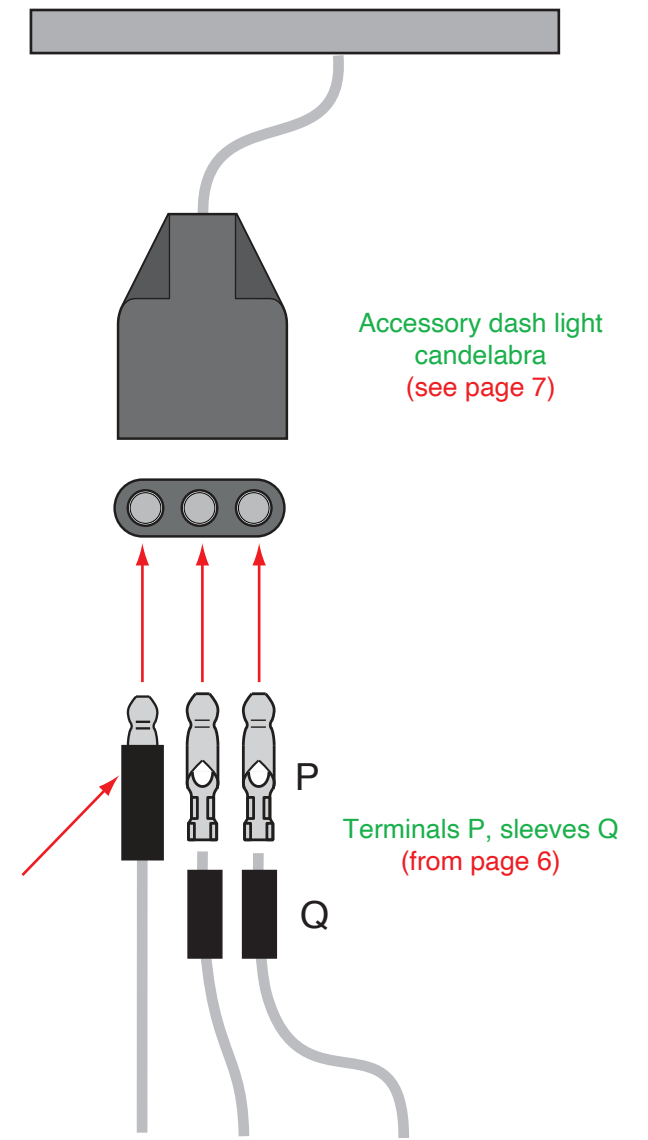

## Accessory Connector:

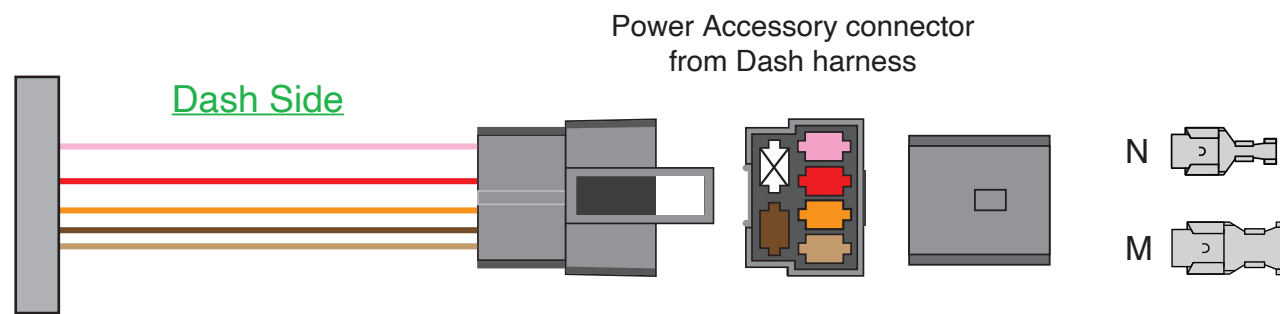

6-way empty connector (removed from Dash harness connector) and terminals "M" or "N" used to connect your power wires (not included in kit) to the dash harness

Use the provided 6-way empty connector, which is attached to the 6-way Accessory connector on the Dash Harness, and terminals "M" and "N" (see Parts Kit 92973236) to add power wires for the following optional systems

Wire Color	Wire Printing	Fuse Block Printing	Fuse Rating	Description
Tan	FUEL PUMP	FUEL	20A	Fused 12 volt IGNITION feed for an electric fuel pump (may also be used to feed power to another ignition circuit).
Orange	12V BATTERY FUSED	BAT2	30A	Fused 12 volt BATTERY feed (may also be used to feed power to another battery circuit).
Red	(no printing)	BAT1	20A	Fused 12 volt BATTERY feed for power locks (may also be used to feed power to another battery circuit).
Pink	12V IGNITION FEED	PWO WDO	25A	Fused 12 volt IGNITION feed for power windows (may also be used to feed power to another ignition circuit).
Brown	IGNITION SW ACCY	ACCY1	30A	Fused 12 volt ACCY. feed (may also be used to feed power to another accessory circuit).



www.americanautowire.com 856-933-0801

**1971-80 IH Scout**  
**510838**

*Classic Update Series*

92973231 Rev 1.0 10/14/2024



# 510839 Dash/Main harness installation instructions:

## AMERICAN AUTOWIRE DASH HARNESS TURN SIGNAL SWITCH CONNECTOR

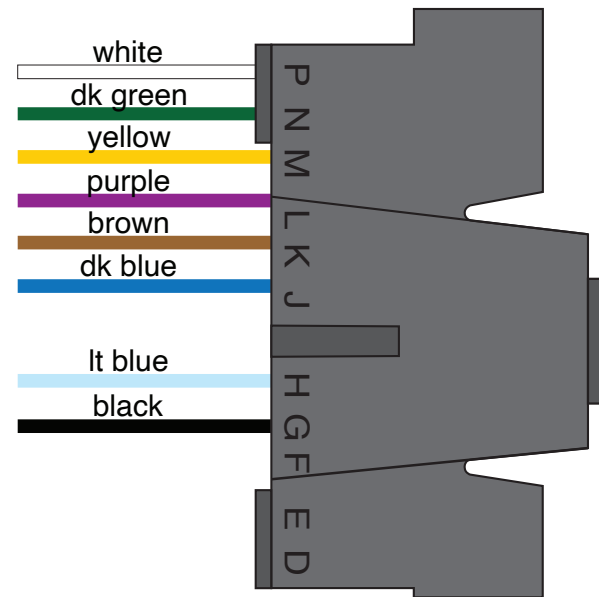

## STOCK 1971-80 or AFTERMARKET TURN SIGNAL SWITCH WIRING

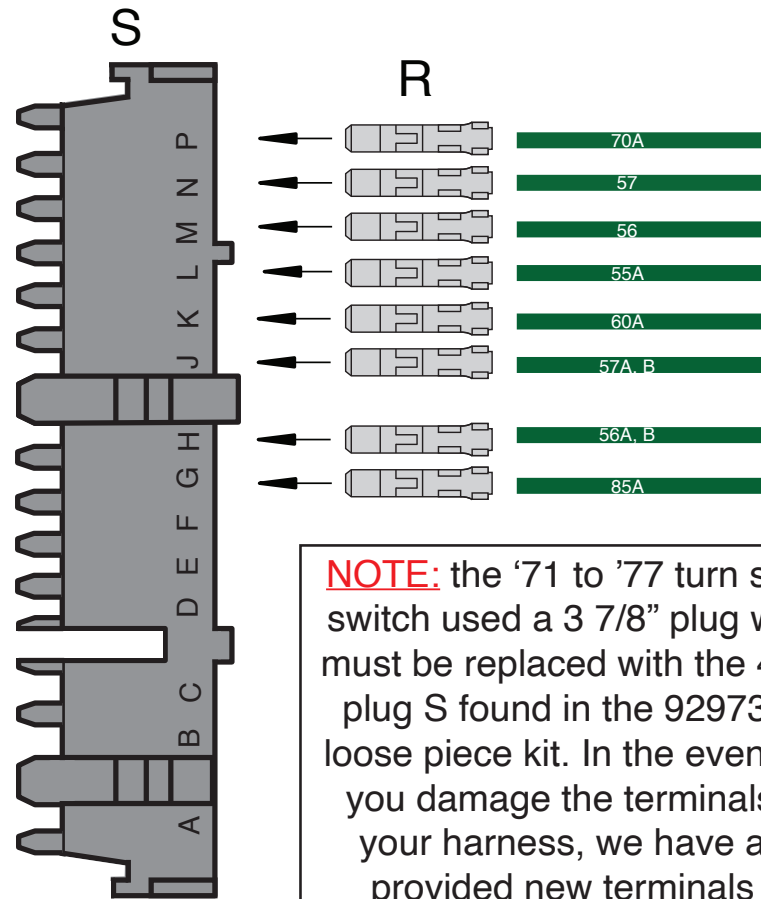

**NOTE:** the '71 to '77 turn signal switch used a 3 7/8" plug which must be replaced with the 4 1/4" plug S found in the 92973236 loose piece kit. In the event that you damage the terminals on your harness, we have also provided new terminals R.

This diagram is to connect the AAW turn signal dash harness connection to a stock 1971-77 or some **aftermarket** steering columns. If you have a **stock** 1978-80 steering column, or a reproduction turn signal switch, the AAW Turn Signal switch connector will plug directly into it with no modifications needed.

## Required steering column connector modification for OEM and some aftermarket steering columns

### "Table B"

Dash harness turn signal switch wires to aftermarket or stock 1971 - 80 turn signal switch

AAW Wire Color	AAW Wire Printing	Connector Cavity	Original Wire Color
White	Brake SW	P	Dark Green 70A
Dark Green	Right Rear Turn	N	Dark Green 57
Yellow	Left Rear Turn	M	Dark Green 56
Purple	Turn Switch Feed	L	Dark Green 55A
Brown	Turn SW – Hazard	K	Dark Green 60A
Dark Blue	Right Front Turn	J	Dark Green 57A,B
Light Blue	Left Front Turn	H	Dark Green 56A,B
Black	Horn Relay Ground	G	Dark Green 85A
N/A	None	F	None
N/A	None	E	None
N/A	None	D	None

1. Remove the **aftermarket or stock 1971-77** turn signal switch connector and replace it with the AAW 14-way connector "S" from page 6. Crimp terminal "R" onto each of the original turn signal switch wires, and plug them into connector "S" as shown at left. (see parts kit **92973236**).
2. Use "Table B" above to align the wires.
3. Note: The steering column horn button switches ground for the horn relay, which then switches power to the horns.



**1971-80 IH Scout**  
**510838**

*Classic Update Series*

# 510839 Dash/Main harness installation instructions:



www.americanautowire.com 856-933-0801

VSS dash jumper connection to the 500730 VSS lead wire kit:

## Electric Speedo VSS connection:

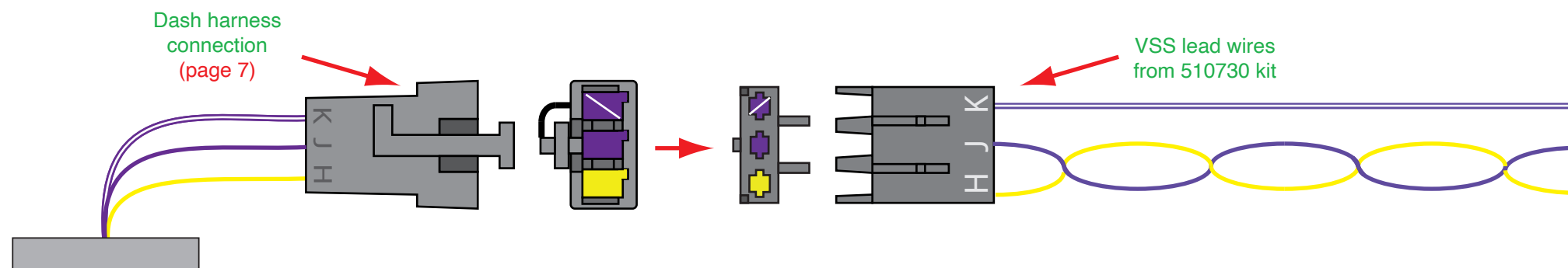

If you are using an aftermarket electric speedometer in your vehicle, you will need to connect the vehicle speed sensor (VSS) Lead Wires from the 510730 kit to the dash side connection of your dash harness. The yellow and solid purple wires must remain twisted together as shown above. These three wires will need to pass through the firewall or floor of your vehicle down to the vehicle speed sensor unit in the transmission. Generally, the solid purple wire connects to the "signal" lead, the yellow wire connects to the "ground" lead, and the purple/white stripe wire connects to the "12 volt power" lead on the vehicle speed sensor assembly. However, you should consult the directions that came with your gauges, and connect your vehicle speed sensor per the manufacturer's instructions.

## Radio wire connections:

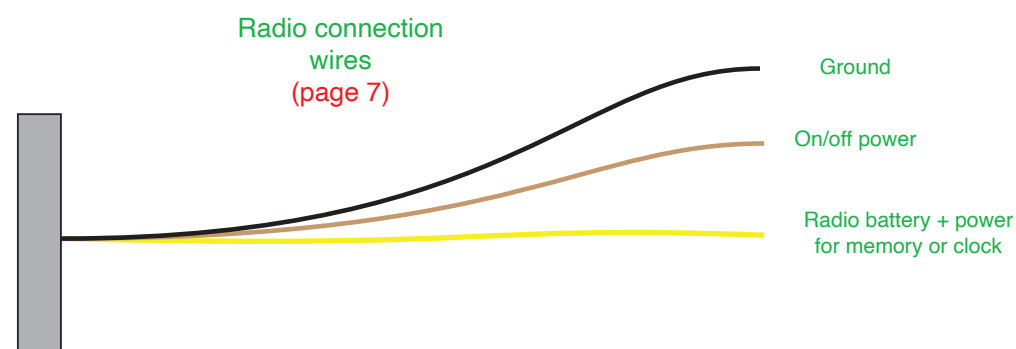

**NOTE:** These (3) wires will be used to hook-up your radio. The black is the radio ground, the tan is the "keyed" on/off power feed, and the yellow is the battery+ feed that is hot at all times and would be used for the digital read-out or memory feature on an electronically controlled radio.

## 12V Ignition and tach wire connections for cabin mounted ECU:

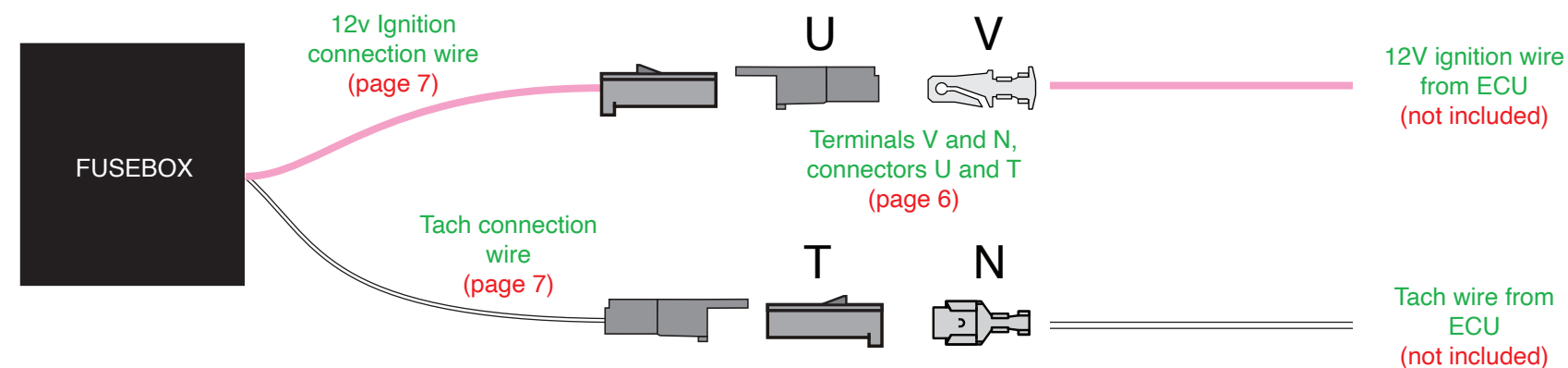

**Connecting the new dash harness 12V ignition and tach wires to a cab mounted ECU harness (if so equipped):**

1. If you have an ECU harness mounted inside your truck, attach the pink 12V IGN wire just off the fuseox to the 12V ignition input wire from your ECU harness.
2. If you have an ECU harness mounted inside your truck, attach the white COIL/TACH wire just off the fuseox to the tach output wire from your ECU harness.

(terminals V, N and connectors U, T have been have been provided)

**1971-80 IH Scout**  
**510838**

*Classic Update Series*

92973231 Rev 1.0 10/14/2024

# 510839 Dash/Main harness installation instructions:

## Windshield wiper and washer switch connections:

**NOTE:** Listed below are the functions of each of the 5 wiper/washer wires:

1. The blue wire is the fused 12v power feed from the fuse box to the switch.
2. The green wire is the "park" feed from the switch to the wiper motor.
3. The black wire is the "high speed" feed from the switch to the wiper motor.
4. The white wire is the 12v feed from the switch to the washer pump.
5. The red wire is the "low speed" feed from the switch to the wiper motor.

Plug in as shown below to complete the wiper/washer switch connections.

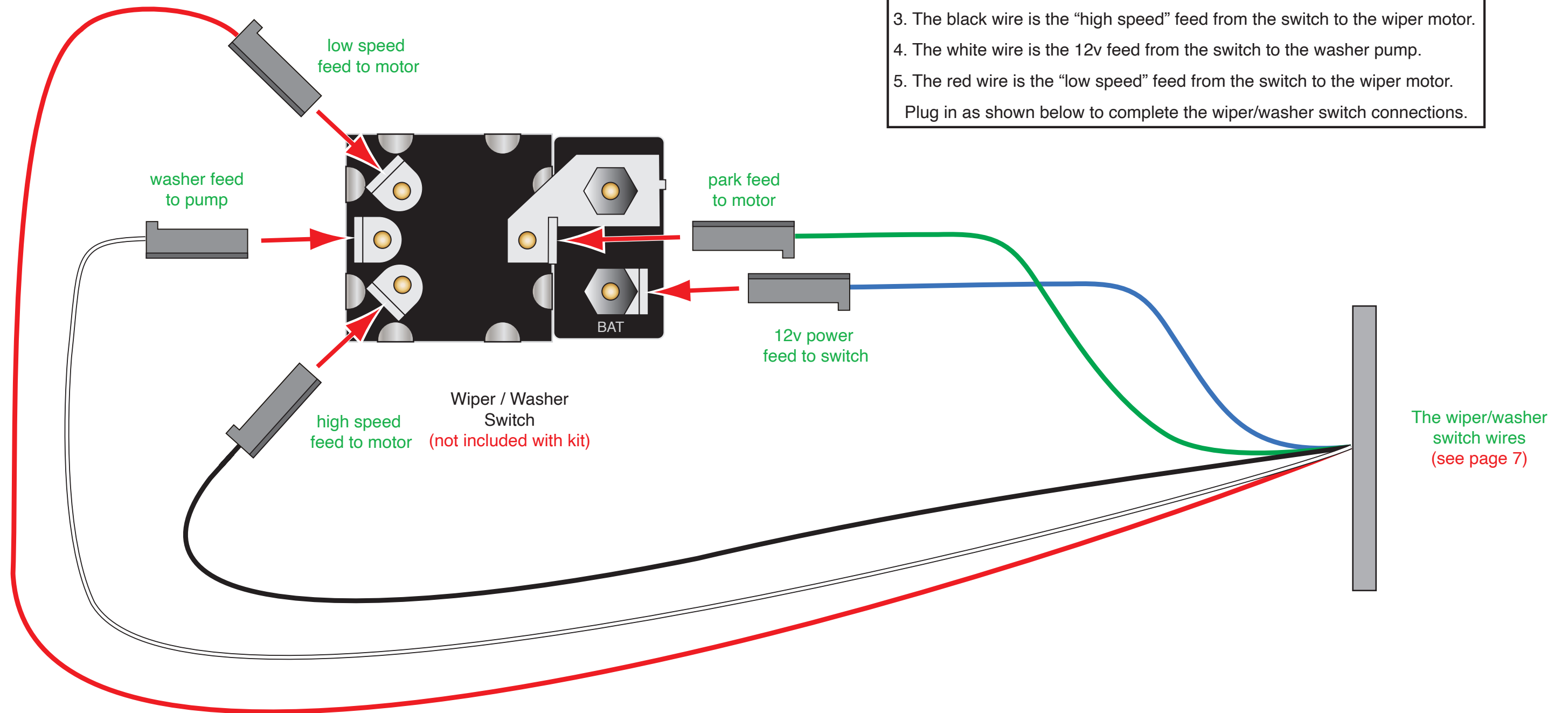

www.americanautowire.com 856-933-0801

**1971-80 IH Scout**  
**510838**

*Classic Update Series*

92973231 Rev 1.0 10/14/2024

# 510839 Dash/Main harness installation instructions:



www.americanautowire.com 856-933-0801

## Transmission mounted back-up switch connections:

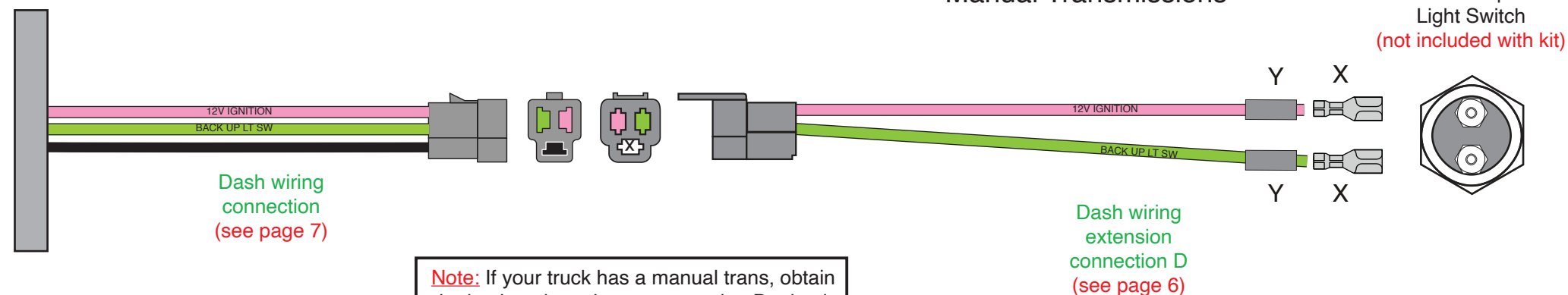
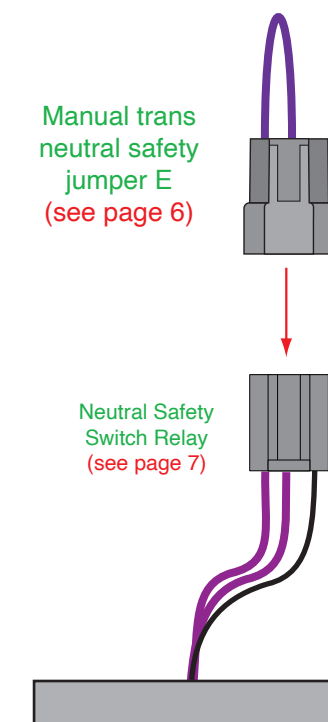

**FIGURE "A"**  
Back-up Light Switch for Manual Transmissions

**Note:** If your truck has a manual trans, obtain the back up lamp jumper extension D, plug it into the main dash harness as shown above, route the loose end of the wires out through the firewall, and down to the transmission. Connect these wires to your transmission switch using terminals X and sleeves Y. (extension D, terminals X and sleeves Y are found on page 6)

**FIGURE "B"**  
Neutral Safety Jumper for Manual Transmissions

**Note:** If your truck has a manual transmission, you will need to obtain the NSS jumper E from page 6 and plug it onto the neutral safety switch relay connection from page 7 to complete the start/crank circuit. If you fail to do this, your truck will not start.



## Transmission mounted back-up and neural safety switch connections:



**FIGURE "C"**  
Back-up Light Switch/Neutral Safety Switch for Automatic Transmissions

**NOTE:** The center brown/yellow wire must be spliced to the black wire, the pink and lt. green wires may be spliced to either of the other two in the 3-way molded connector.

**Note:** If your truck has an automatic trans, obtain wire J and plug it into the empty cavity of extension D, then plug the completed extension D into the main dash harness as shown above. Route the loose ends of the wires out through the firewall, and down to the transmission. Connect these wires to your transmission switch pigtail as shown above to complete the back up and neutral safety switch circuits. (extension D and wire J are found on page 6. The transmission switch pigtail shown above is not included in this kit, but is available through most parts stores as part number S747 - Standard Motor Products or equivalent)

**Note:** If your truck has an automatic transmission, you will need to plug the neutral safety switch relay connection from page 7 onto the neutral safety switch relay (not included) mounted to the pedal carriage of your vehicle to complete the start/crank circuit. If you fail to do this, your truck will not start.

**1971-80 IH Scout**  
**510838**  
*Classic Update Series*  
92973231 Rev 1.0 10/14/2024

# 510839 Dash/Main harness installation instructions:

## 4WD Transfer case warning lamp switch connections:

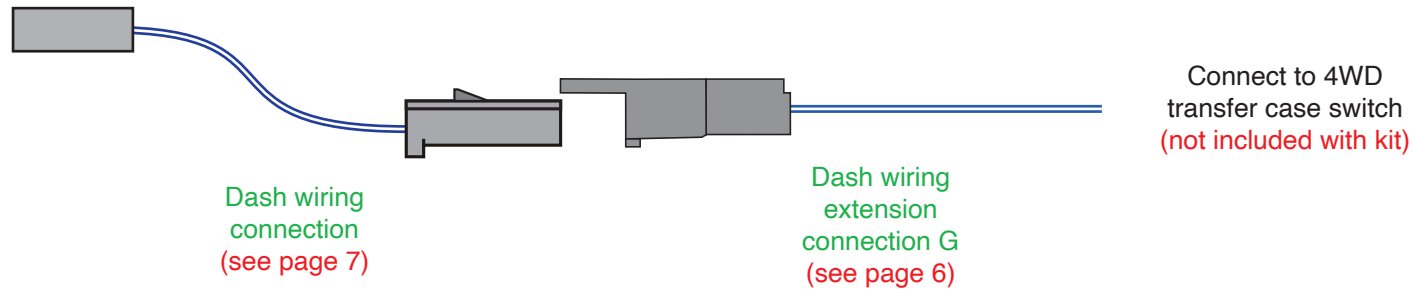

**Note:** If your truck has 4 wheel drive, you will need to obtain extension G (see page 6), plug it onto the dash harness connection as shown on page 7, route the loose end of the wire out through the firewall and down to the transfer case. Connect this wire to your transfer case switch to complete the circuit.  
(terminals and connectors are not included)

## 12V Battery and illumination lamp connections for console:

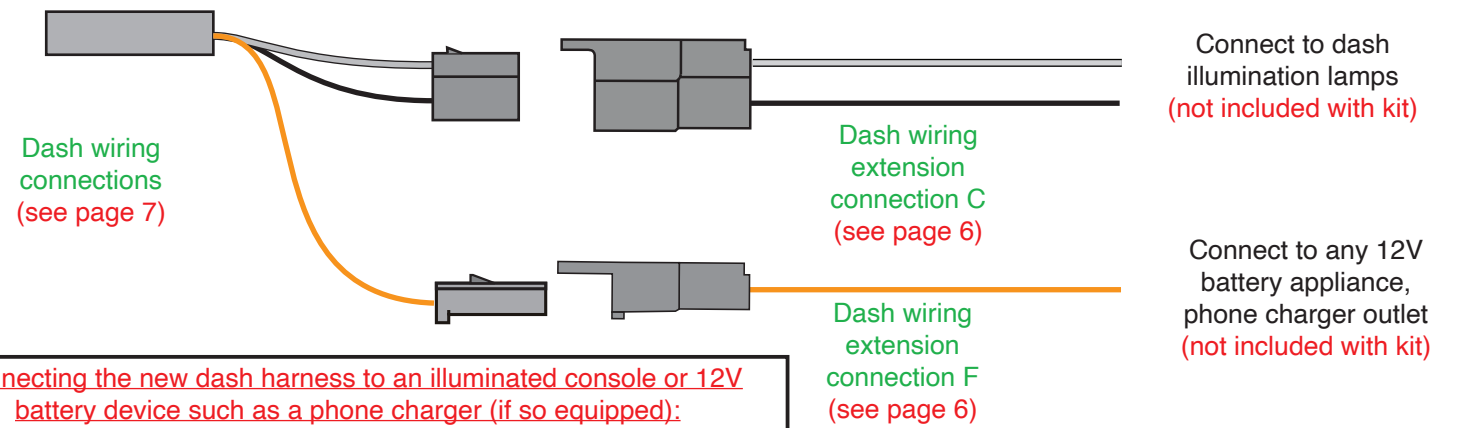

**Connecting the new dash harness to an illuminated console or 12V battery device such as a phone charger (if so equipped):**

1. Connect the 2-way connector with gray and black wires on the dash harness to dash extension C, then route the extension wires to your console or underdash area. Connect the gray wire to the feed, and the black wire to the ground on any PRNDL or dash lighting sockets.
2. Connect the 1-way connector with orange wire on the dash harness to dash extension F, then route the extension wire to your console or underdash area. Connect the orange wire to the feed on any item requiring battery 12v (like a phone charger socket). Use the black wire from number 1 above if a ground wire is needed for the device.

(terminals, connectors, and sockets are not included)

## Fog lamp switch connections:

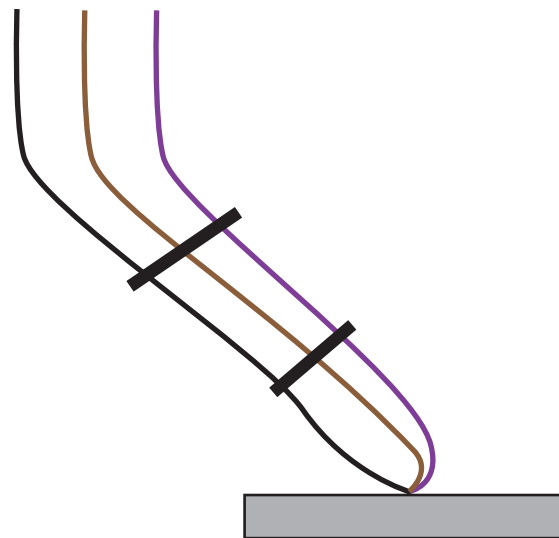

**Connecting the new dash harness to a lighted or unlighted fog lamp switch:**

1. Connect the brown "park lights" wire to the input location on your fog lamp switch.
2. Connect the purple wire to the output location on your fog lamp switch.
3. If your switch has a ground connection, attach the black "ground" wire to the ground location on your fog lamp switch.

(terminals and connectors are not included)

Dash wiring connection (see page 7)

## Windshield wiper motor connection:

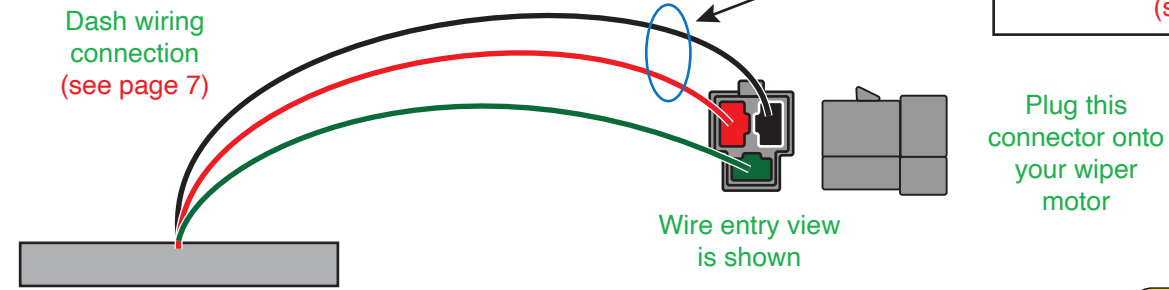

**NOTE:** It may be necessary to switch these two wires in the connector based on the wiper motor you have. (see page 7)

**Connecting the new dash harness to your windshield wiper motor assembly:**

1. Route this pre-assembled 3-way connector with dk. green, red and black wires out through the center hole in your firewall and plug it directly onto your wiper motor assembly. In most applications, no additional work or modification is necessary. However, there were some applications where the black and red wires were reversed at the wiper motor. In those instances, you will need to remove the black and red wires from this connector (after collapsing the locking tab of the terminal), then lifting the tab back up on the removed terminal), and then reinstall them into the connector maintaining color continuity with your wiper motor.



**1971-80 IH Scout**  
**510838**  
*Classic Update Series*  
92973231 Rev 1.0 10/14/2024

# 510839 Dash/Main harness installation instructions:



www.americanautowire.com 856-933-0801

## 1971-77 Blower motor/Blower resistor connections:

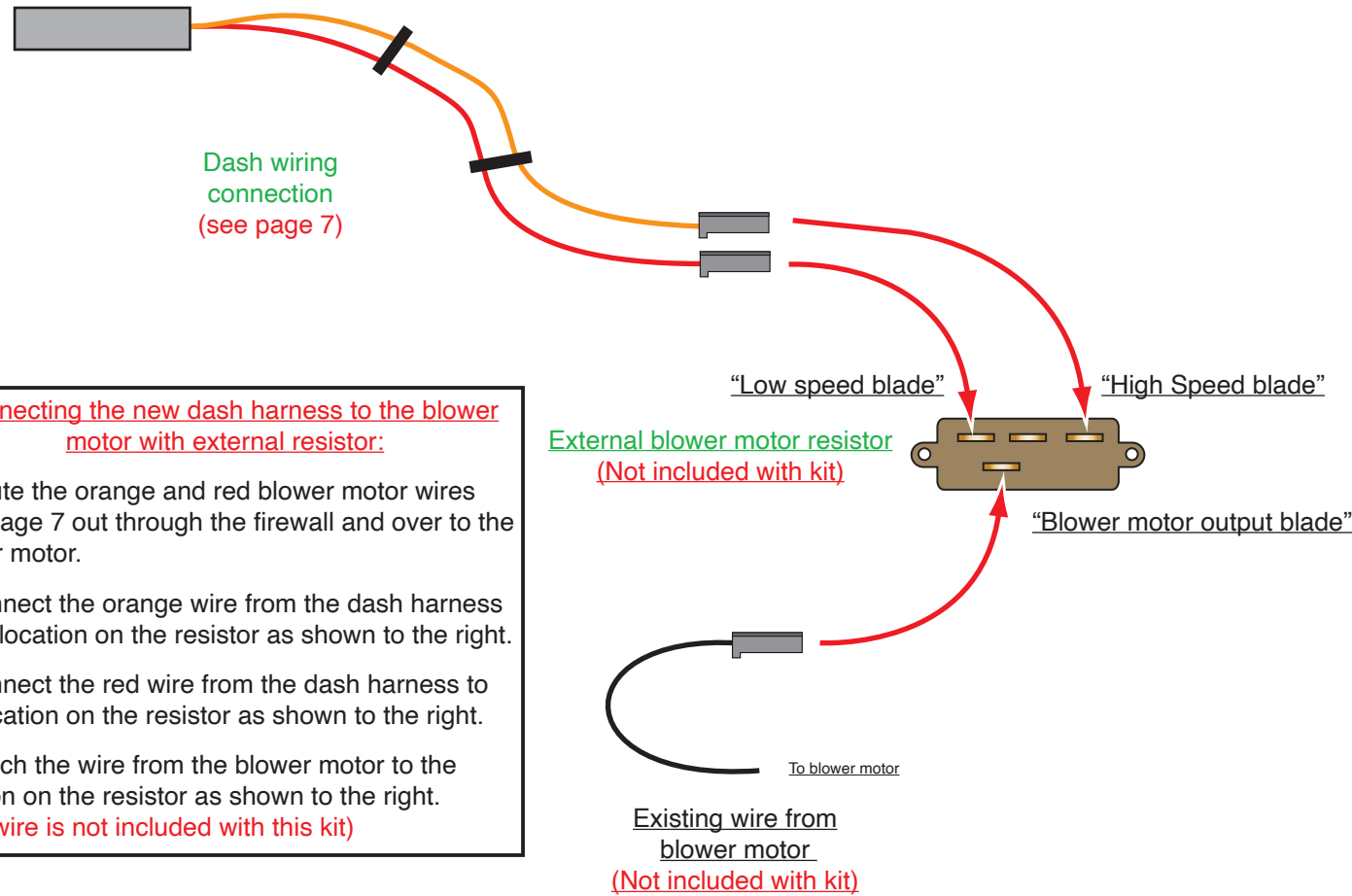

**Connecting the new dash harness to the blower motor with external resistor:**

1. Route the orange and red blower motor wires from page 7 out through the firewall and over to the blower motor.
2. Connect the orange wire from the dash harness to the location on the resistor as shown to the right.
3. Connect the red wire from the dash harness to the location on the resistor as shown to the right.
4. Attach the wire from the blower motor to the location on the resistor as shown to the right. (This wire is not included with this kit)

## 1978-80 Blower motor connections:

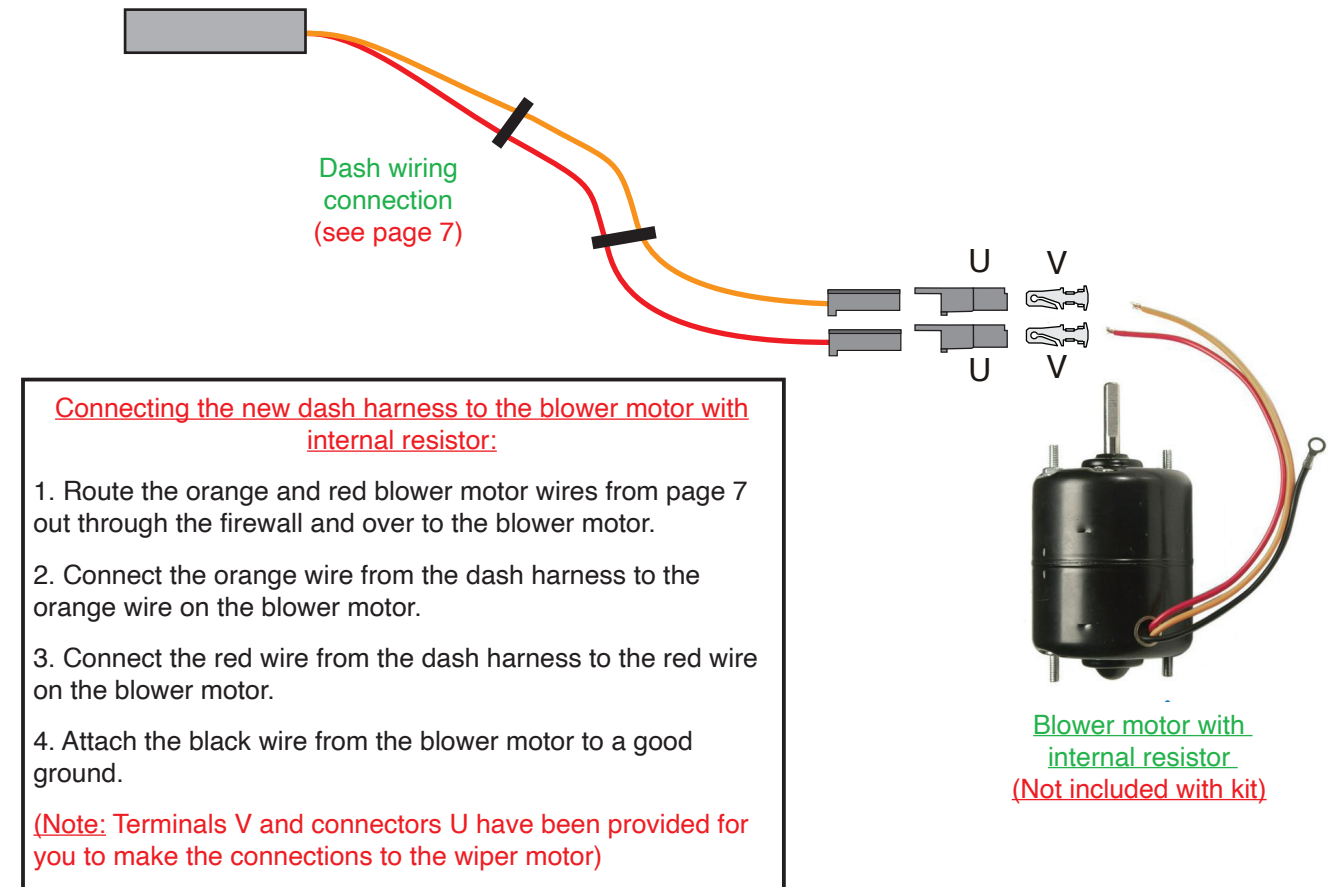

**Connecting the new dash harness to the blower motor with internal resistor:**

1. Route the orange and red blower motor wires from page 7 out through the firewall and over to the blower motor.
2. Connect the orange wire from the dash harness to the orange wire on the blower motor.
3. Connect the red wire from the dash harness to the red wire on the blower motor.
4. Attach the black wire from the blower motor to a good ground.

(Note: Terminals V and connectors U have been provided for you to make the connections to the wiper motor)

## Dash side fuel pump connection:

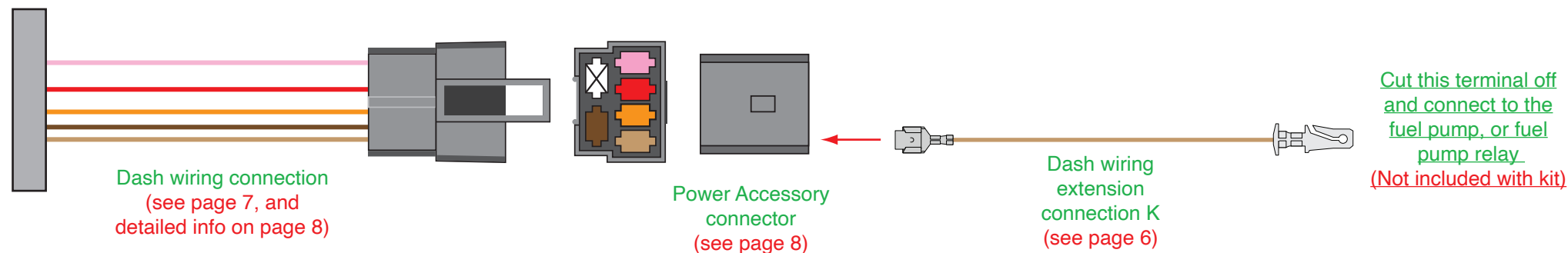

**Connecting the new dash harness to an electric fuel pump or fuel pump relay:**

**NOTE:** This new harness is wired so that you can use an internal fuel pump feed connection, or one that attaches outside the vehicle under the hood. This instruction is to make the connection inside the cabin of the truck to the 6-way accessory connection found on pages 7 and 8. If you wish to wire the fuel pump feed under the hood, see page 23 for detailed installation instructions.

1. Obtain the fuel pump jumper wire found on page 6 and plug it into the 6-way accessory plug found on pages 7 and 8 maintaining continuity with the dash harness as shown at the left.
2. Cut the male terminal off the other end of this wire, and attach it to your electric fuel pump or electric fuel pump relay following the manufacturers directions.



www.americanautowire.com 856-933-0801

**1971-80 IH Scout**  
**510838**  
 Classic Update Series  
 92973231 Rev 1.0 10/14/2024

# 510840 Gauge Cluster harness installation instructions:

Below are the supplied harnesses, terminals and connector bodies included in the Gauge Cluster Harness 510840 and Loose Piece bag. These will be used to complete your gauge cluster connections and are referenced by the letters and descriptions below from this point forward.

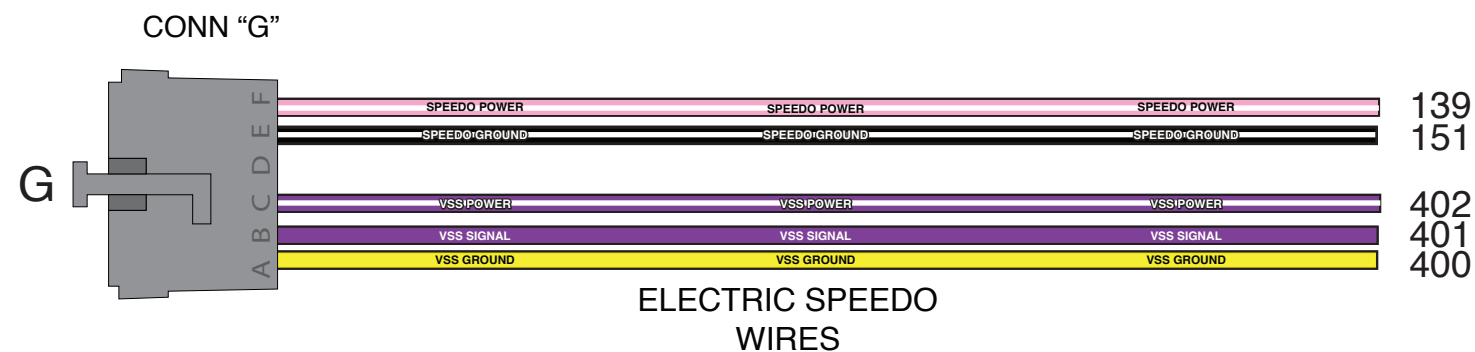
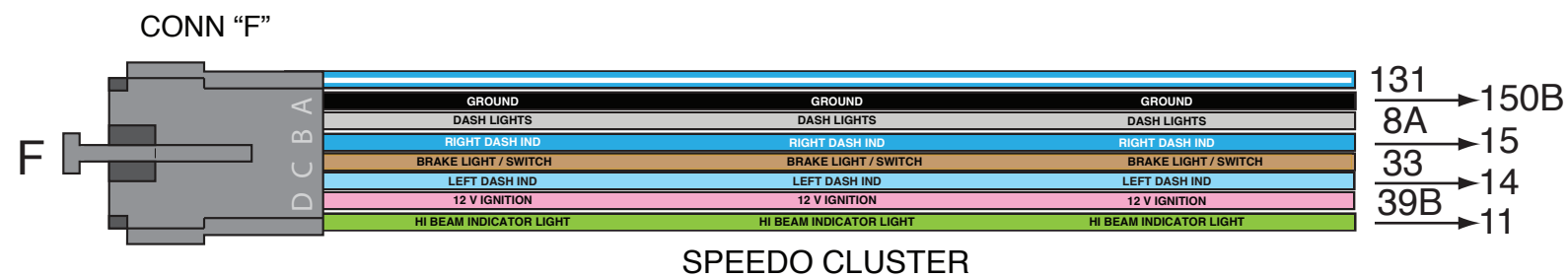
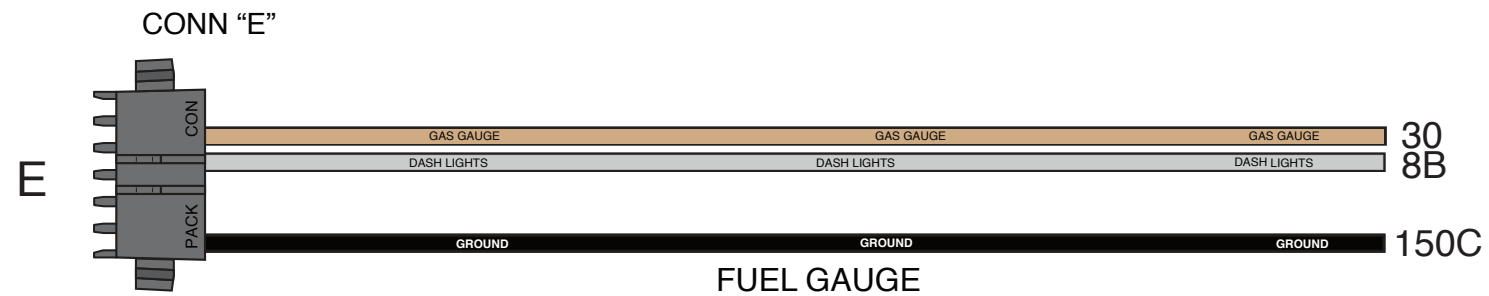
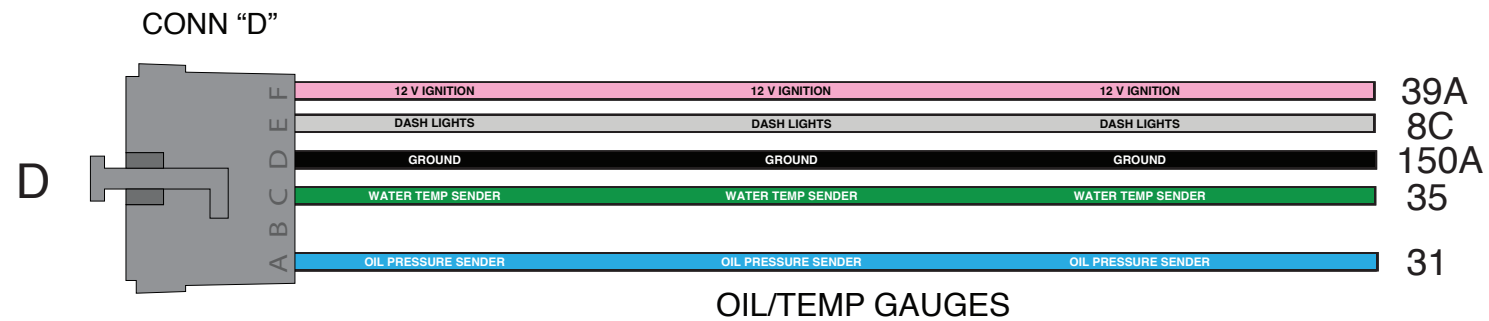

- H COIL -> TACH 121
- J 239A
- K 239B
- L 12V IGNITION 39C
- M (connector, P/C brd F x 9, 3 pcs)
- N (terminal, F Pin, 20 pcs)



www.americanautowire.com 856-933-0801

**1971-80 IH Scout**  
**510838**  
*Classic Update Series*  
 92973231 Rev 1.0 10/14/2024

# 510840 Gauge Cluster harness installation instructions:

## OIL PRESSURE AND TEMPERATURE GAUGE CLUSTER, ALL YEARS

## GAS GAUGE AND AMMETER (NOT SUPPORTED) GAUGE CLUSTER, ALL YEARS

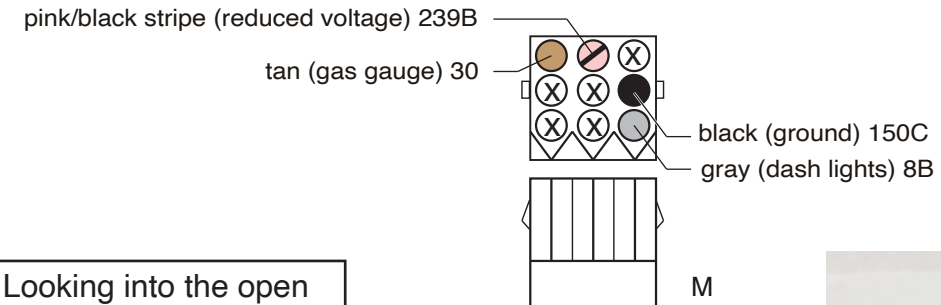
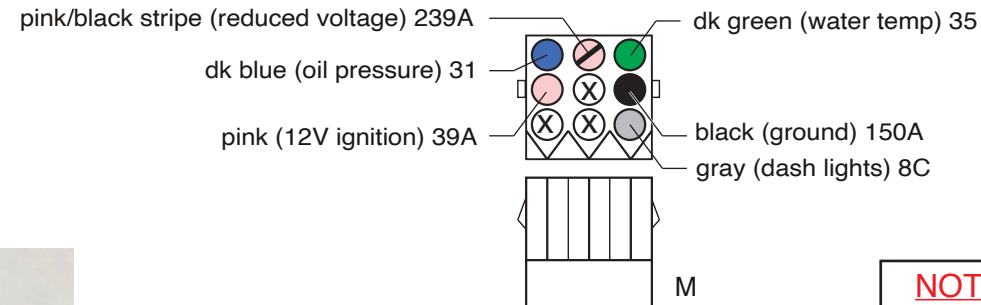
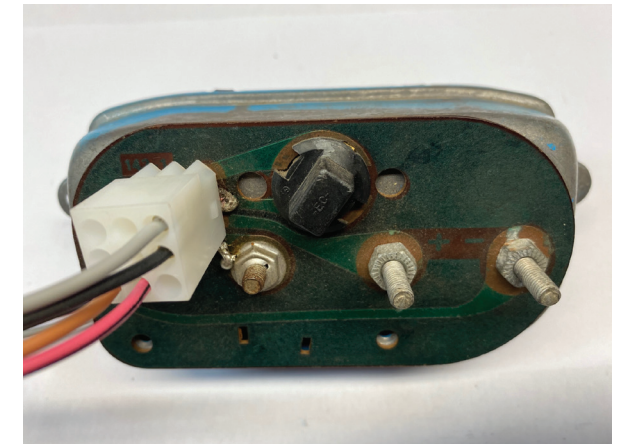
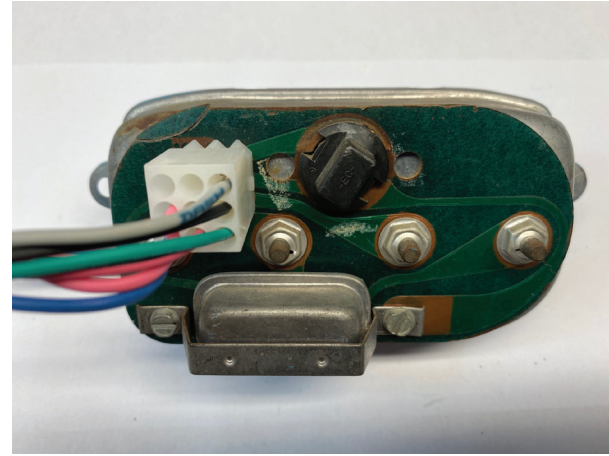

**NOTE:** Looking into the open end of the connectors with the wires going away from you.

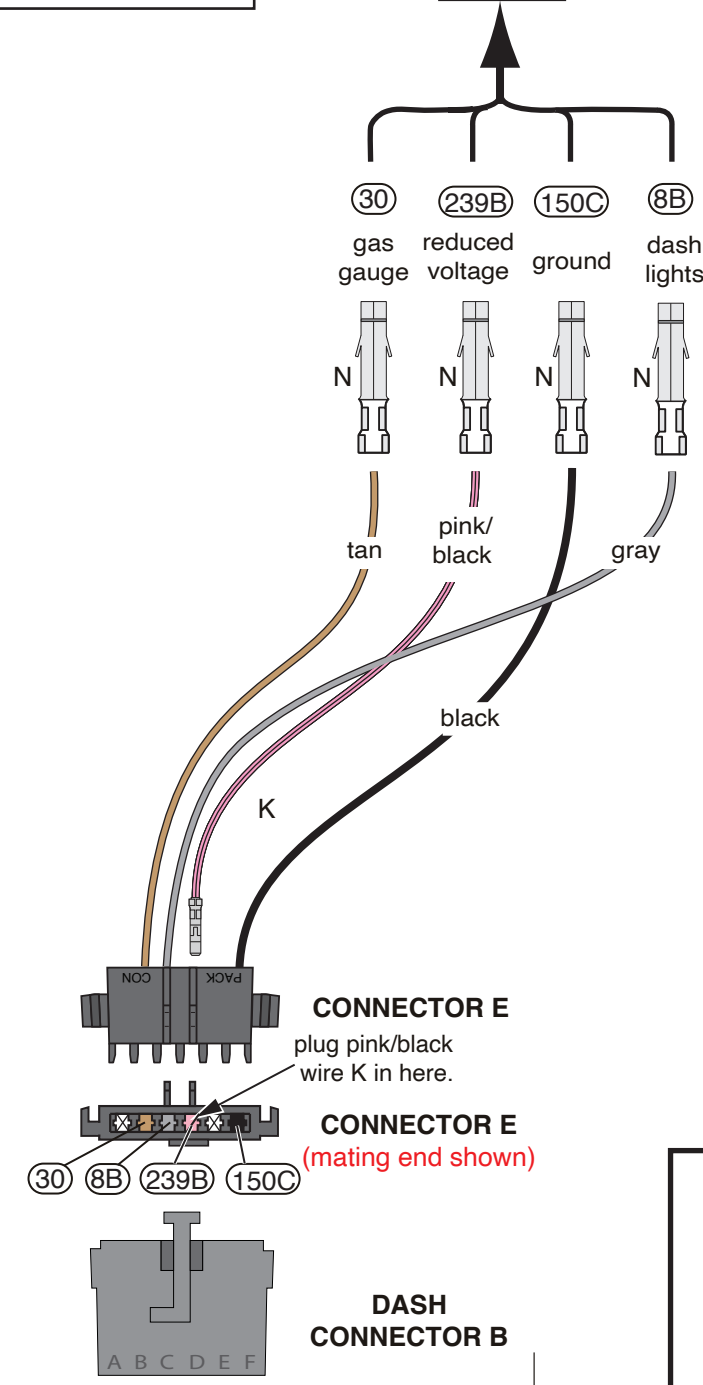
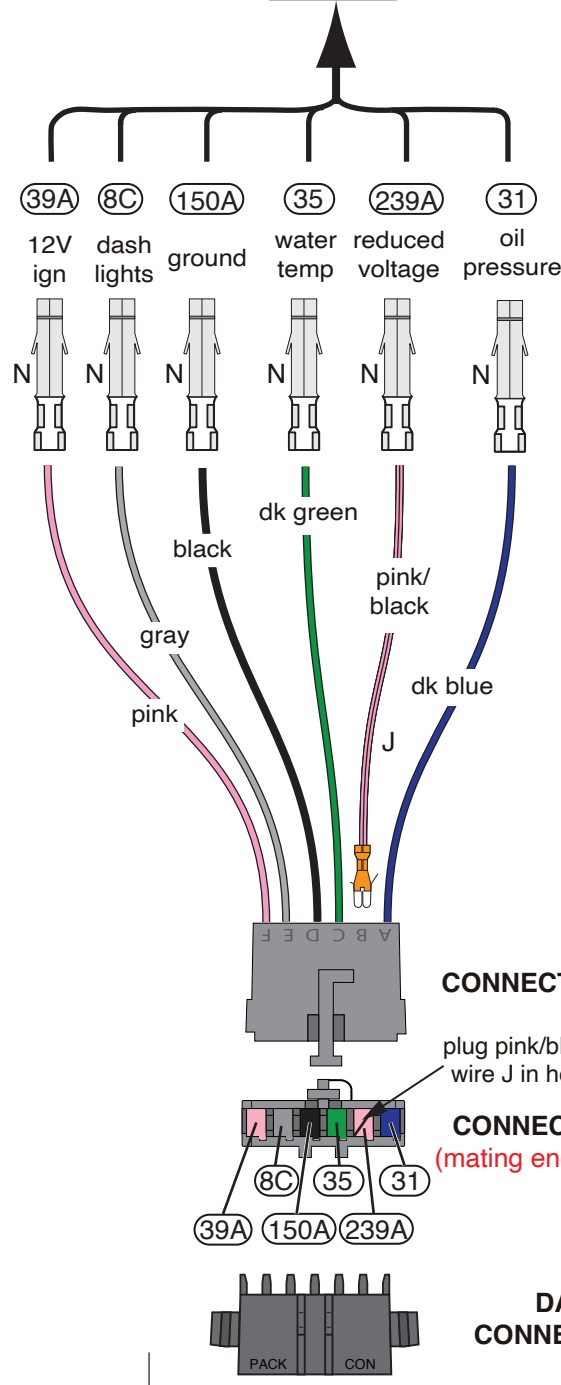

**Helpful Hint:** The new terminals N fit onto the factory circuitboard pins very tightly. After installing new terminals N into connector M as shown at the right, we recommend inserting either a pic or an awl into the open end of each terminal to open them up a slight bit. This will help the connector install onto the circuitboard easier.



www.americanautowire.com 856-933-0801

**1971-80 IH Scout**  
**510838**  
Classic Update Series  
92973231 Rev 1.0 10/14/2024



# 510840 Gauge Cluster harness installation instructions:

**Helpful Hint:** The new terminals N fit onto the factory circuitboard pins very tightly. After installing new terminals N into connector M as shown at the right, we recommend inserting either a pic or an awl into the open end of each terminal to open them up a slight bit. This will help the connector install onto the circuitboard easier.

## SPEEDOMETER CLUSTER, ALL YEARS

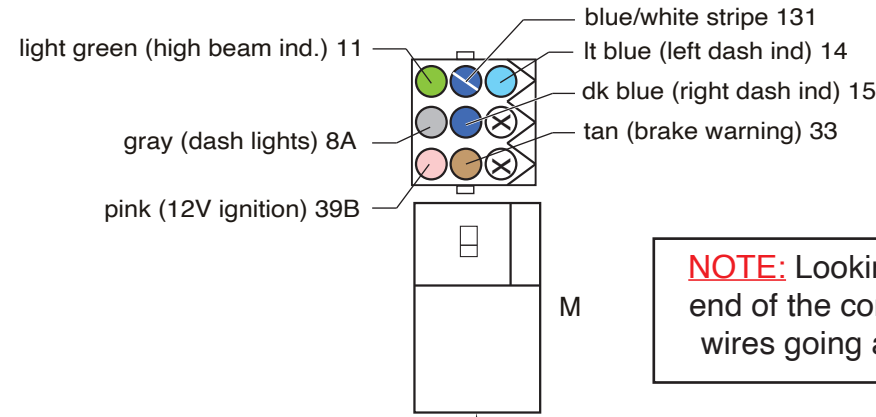

**NOTE:** Looking into the open end of the connector with the wires going away from you.

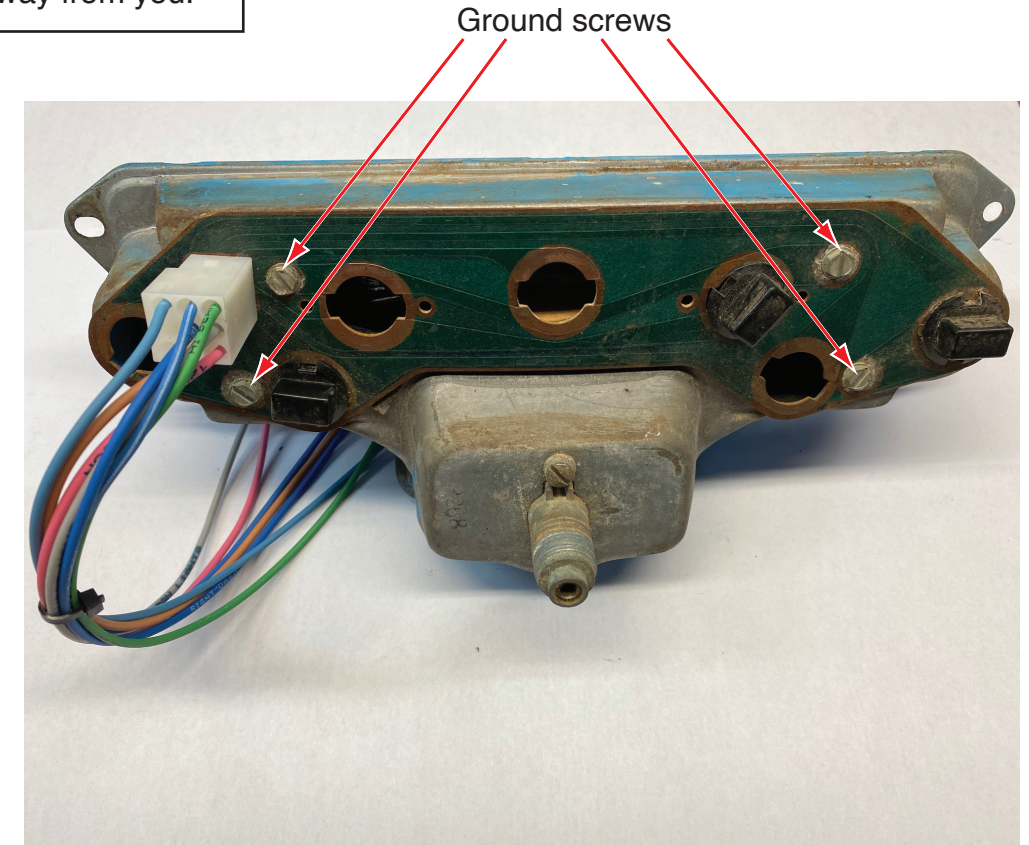
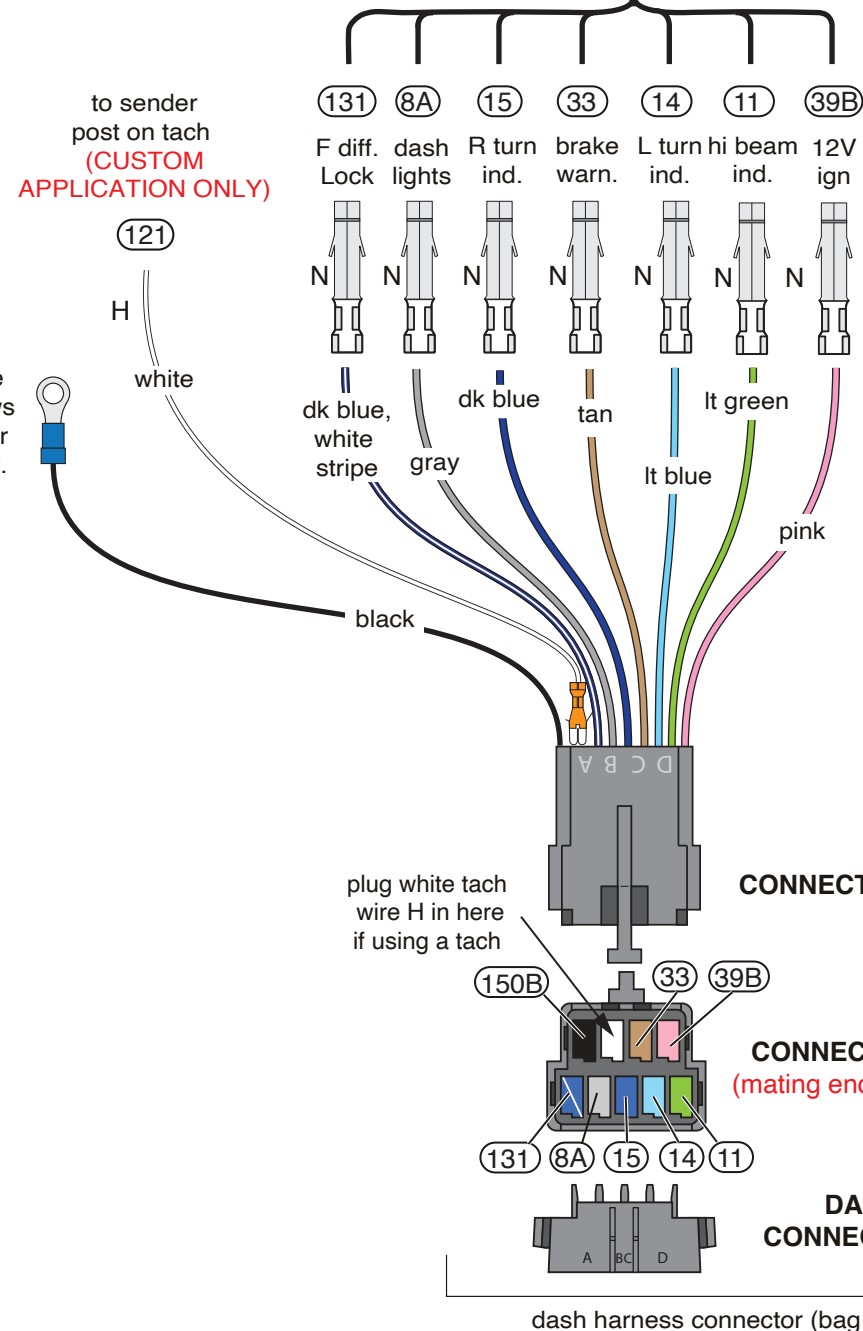

www.americanautowire.com 856-933-0801

**1971-80 IH Scout**  
**510838**  
*Classic Update Series*  
92973231 Rev 1.0 10/14/2024

# 510840 Gauge Cluster harness installation instructions:

SHOWN BELOW IS A TYPICAL **AFTERMARKET GAUGE** INSTALLATION PROCEDURE. FOLLOW THE MANUFACTURER'S INSTRUCTIONS FOR BEST RESULTS.

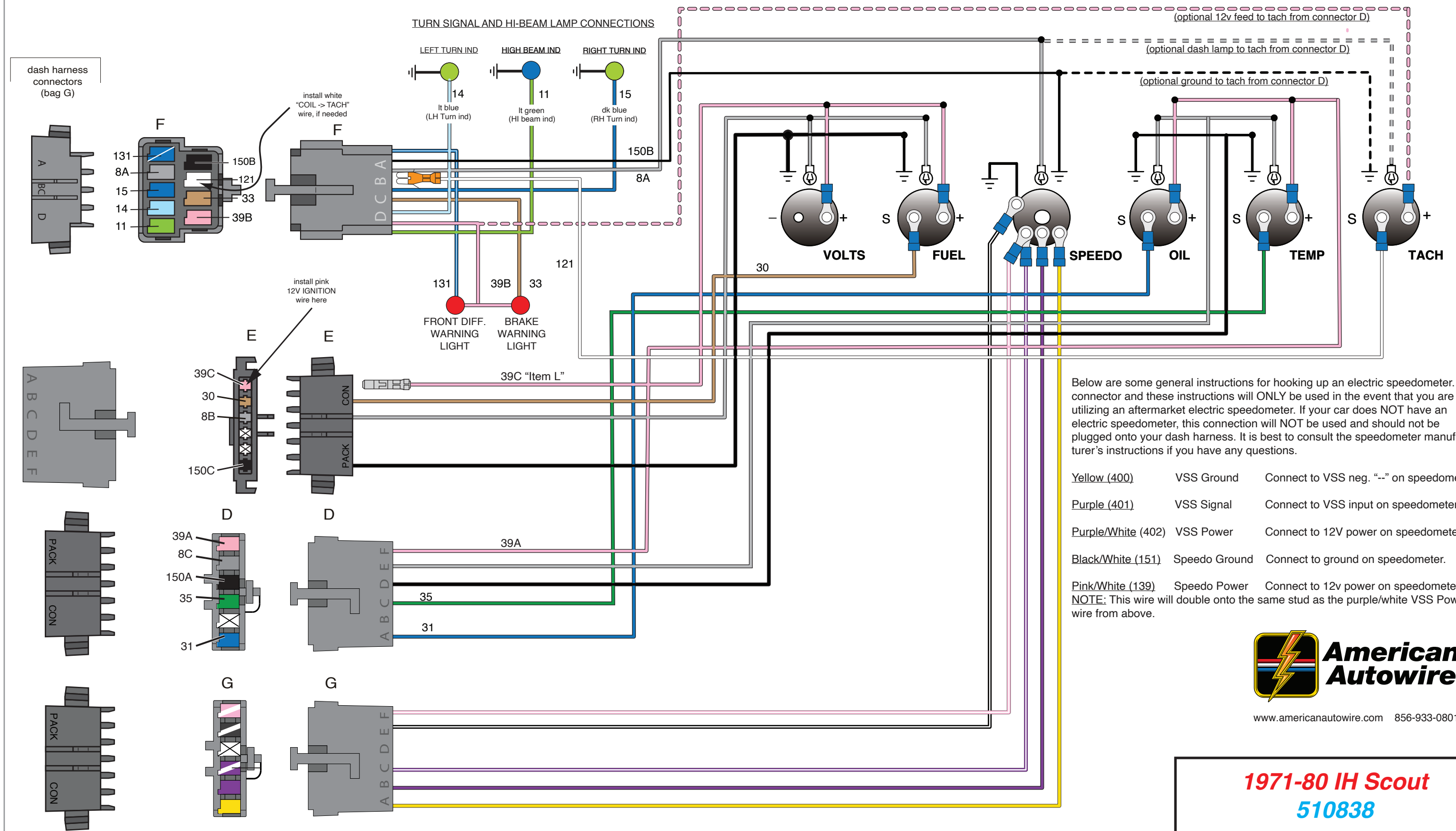

Below are some general instructions for hooking up an electric speedometer. This connector and these instructions will ONLY be used in the event that you are utilizing an aftermarket electric speedometer. If your car does NOT have an electric speedometer, this connection will NOT be used and should not be plugged onto your dash harness. It is best to consult the speedometer manufacturer's instructions if you have any questions.

- Yellow (400)** VSS Ground Connect to VSS neg. "--" on speedometer.
- Purple (401)** VSS Signal Connect to VSS input on speedometer.
- Purple/White (402)** VSS Power Connect to 12V power on speedometer.
- Black/White (151)** Speedo Ground Connect to ground on speedometer.
- Pink/White (139)** Speedo Power Connect to 12v power on speedometer.  
NOTE: This wire will double onto the same stud as the purple/white VSS Power wire from above.



www.americanautowire.com 856-933-0801

**1971-80 IH Scout**  
**510838**  
*Classic Update Series*  
92973231 Rev 1.0 10/14/2024

# 510841 Engine harness installation instructions:

Below are the supplied terminals, connector bodies, pigtail assemblies, and assorted components included in the 510841 Engine Harness and Loose Piece bags. These will be used to complete your Engine Harness connections as shown on page 20 through 23, and are referenced by the letters and descriptions below.

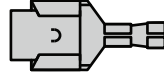
A  (terminal, 56 series single female, 13 pcs)

B  (terminal, 56 series double female, 5 pcs)

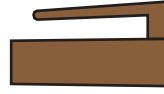
C  (connector, 56 series, 1-way female, 1 pc)

D  (connector w/notch, 56 series single female, 2 pcs)

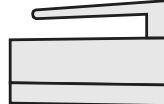
E  (connector, 56 series, 1-way female, 1 pc)

F  (Sleeve, rubber large, 6 pcs)

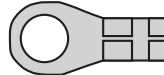
G  (Ring terminal, M5, 10-12 Ga., 5 pcs)

H  (Sleeve, rubber small, 5 pcs)

J  (Ring terminal, M5, 14-16 Ga., 6 pcs)

K  (Electric choke wire, 1 pc)

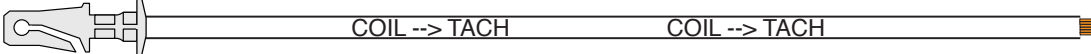
L  (Coil wire, 1 pc)

M  (Alternator exciter wire, 1 pc)

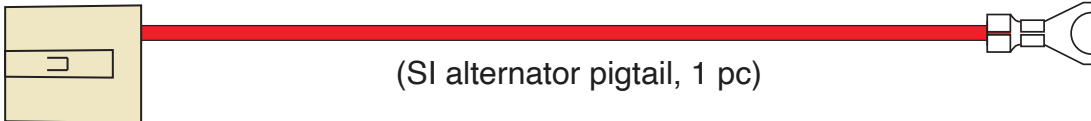
N  (SI alternator pigtail, 1 pc)

P  (A/C compressor lead wire, 1 pc)

X  (Fuel Pump Jumper Wire)  
 (for reference only, see dash instructions on page 6 and installation instructions on page 23)



www.americanautowire.com 856-933-0801

**1971-80 IH Scout**  
**510838**

*Classic Update Series*

92973231 Rev 1.0 10/14/2024

# 510841 Engine harness installation instructions:

## 1971-74 stock V-8 or 6 with Davis Unified Distributor or points



www.americanautowire.com 856-933-0801

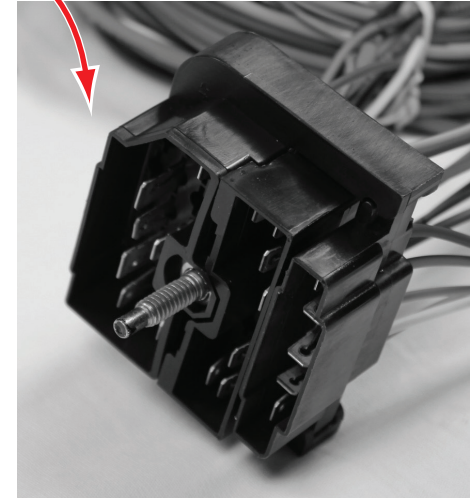
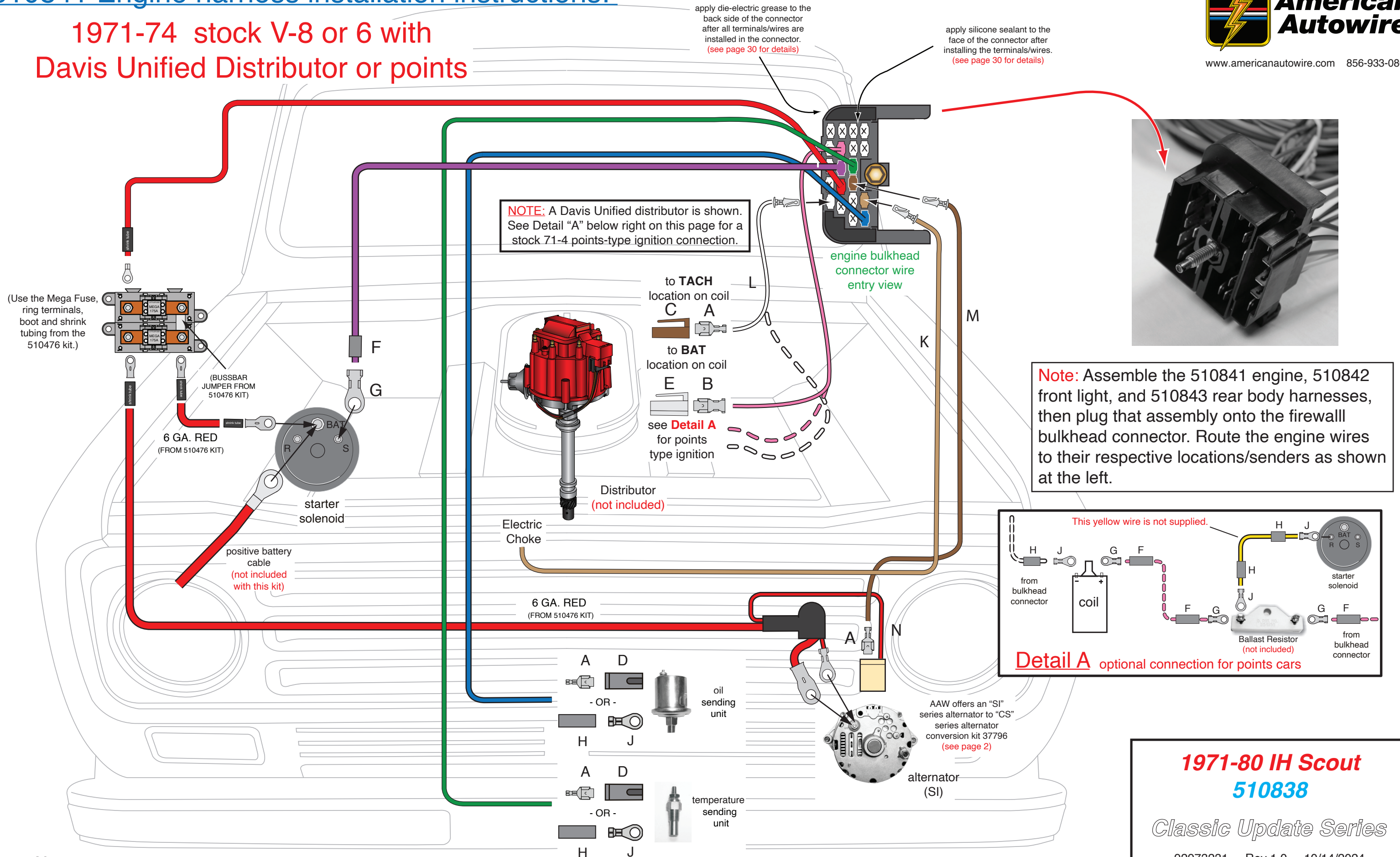

**Note:** Assemble the 510841 engine, 510842 front light, and 510843 rear body harnesses, then plug that assembly onto the firewall bulkhead connector. Route the engine wires to their respective locations/senders as shown at the left.

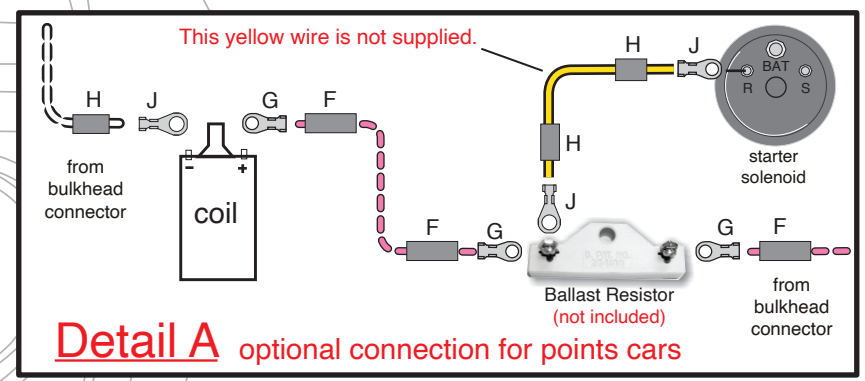

**1971-80 IH Scout**  
**510838**  
*Classic Update Series*  
 92973231 Rev 1.0 10/14/2024

# 510841 Engine harness installation instructions:

## 1974-77 stock V-8 or 6 with "Gold Box" Electronic Ignition



www.americanautowire.com 856-933-0801

(Use the Mega Fuse, ring terminals, boot and shrink tubing from the 510476 kit.)

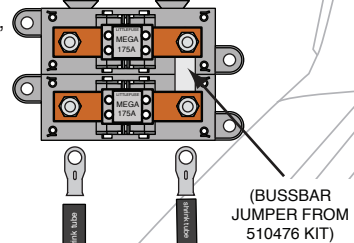

6 GA. RED  
(FROM 510476 KIT)

positive battery cable  
(not included with this kit)

starter solenoid

BAT

R S

(BUSSBAR JUMPER FROM 510476 KIT)

shrink tube

ring terminal

apply die-electric grease to the back side of the connector after all terminals/wires are installed in the connector.  
(see page 30 for details)

apply silicone sealant to the face of the connector after installing the terminals/wires.  
(see page 30 for details)

engine bulkhead connector wire entry view

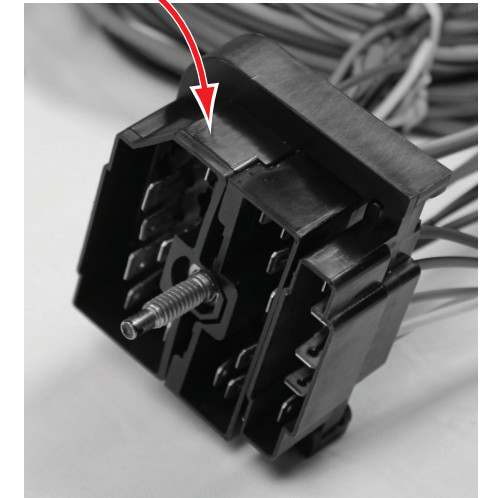

**Note:** Assemble the 510841 engine, 510842 front light, and 510843 rear body harnesses, then plug that assembly onto the firewall bulkhead connector. Route the engine wires to their respective locations/senders as shown at the left.

**NOTE:** An electronic distributor and Gold Box Ignition module are shown. The AAW pink "coil" lead needs to be connected to the black lead that mates with the red wire at the gold box connection, and to the "+" location on the coil. The black wire that mates with the brown wire at the gold box connection connects to the "-" location on the coil.

**NOTE:** White wire not used.

The Gold Ignition box and leads are **NOT** included with this kit.

Distributor (not included)

Electric Choke

6 GA. RED  
(FROM 510476 KIT)

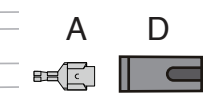

- OR -

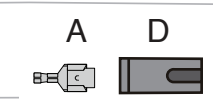

- OR -



H

J



oil sending unit

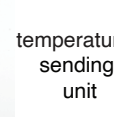

temperature sending unit

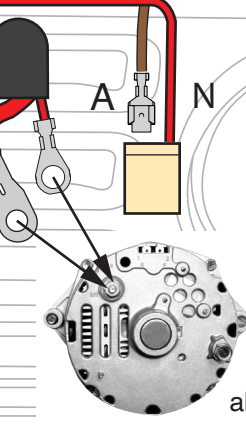

alternator (SI)

AAW offers an "SI" series alternator to "CS" series alternator conversion kit 37796  
(see page 2)

**1971-80 IH Scout**  
**510838**  
*Classic Update Series*  
92973231 Rev 1.0 10/14/2024

# 510841 Engine harness installation instructions:

## 1978-80 stock V-8 or 6 with Prestolite Electronic Ignition



www.americanautowire.com 856-933-0801

(Use the Mega Fuse, ring terminals, boot and shrink tubing from the 510476 kit.)

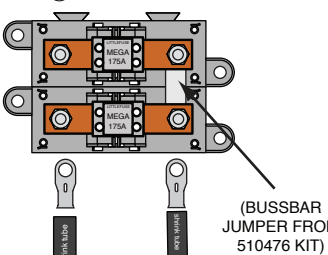

6 GA. RED (FROM 510476 KIT)

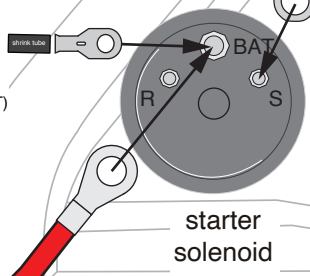

positive battery cable (not included with this kit)

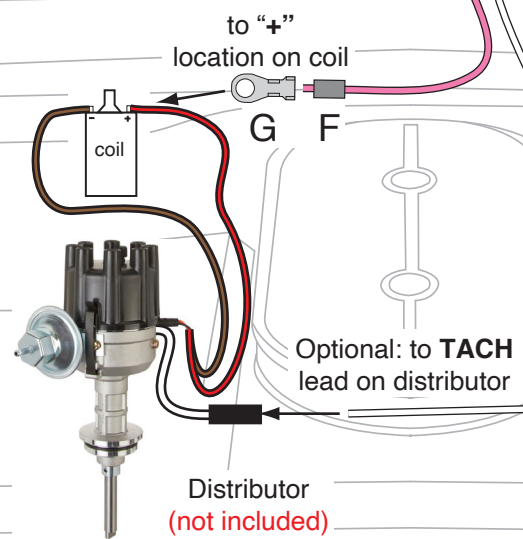

Distributor (not included)

Electric Choke

6 GA. RED (FROM 510476 KIT)

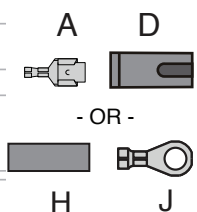
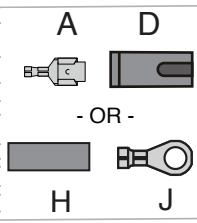

oil sending unit



temperature sending unit

apply die-electric grease to the back side of the connector after all terminals/wires are installed in the connector. (see page 30 for details)

apply silicone sealant to the face of the connector after installing the terminals/wires. (see page 30 for details)

engine bulkhead connector wire entry view

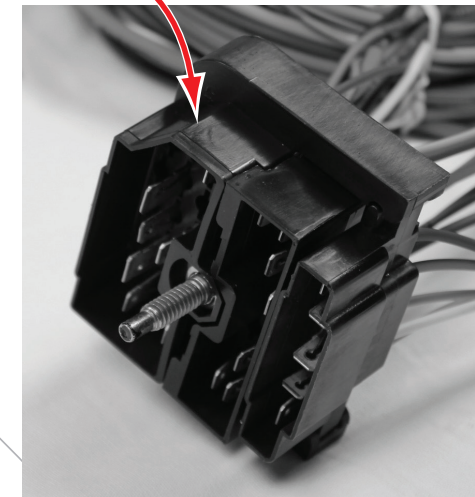

**Note:** Assemble the 510841 engine, 510842 front light, and 510843 rear body harnesses, then plug that assembly onto the firewall bulkhead connector. Route the engine wires to their respective locations/senders as shown at the left.

**NOTE:** A Prestolite distributor is shown. The red lead from the distributor goes onto the "+" coil location. The AAW pink lead goes onto the "+" coil location. The brown lead from the distributor goes onto the "-" coil location.

AAW offers an "SI" series alternator to "CS" series alternator conversion kit 37796 (see page 2)

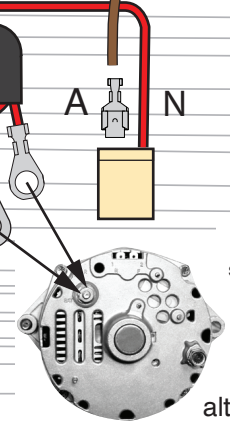

alternator (SI)

**1971-80 IH Scout 510838**

*Classic Update Series*

92973231 Rev 1.0 10/14/2024

# 510841 Engine harness installation instructions:

All applications with electric fuel pump wire under the hood, and/or A/C compressor lead



www.americanautowire.com 856-933-0801

apply die-electric grease to the back side of the connector after all terminals/wires are installed in the connector. (see page 30 for details)

apply silicone sealant to the face of the connector after installing the terminals/wires. (see page 30 for details)

**Note:** Obtain the A/C compressor lead wire "P" found on page 19 of this instruction set, plug it into the location shown at the right, then assemble the 510841 engine, 510842 front light, and 510843 rear body harnesses, and plug that assembly onto the firewall bulkhead connector. Route the other end to your A/C compressor area, and attach it to the A/C compressor clutch.

A/C compressor feed from A/C switch inside of truck

Cut off this terminal and connect this wire to the fuel pump, or fuel pump relay

engine bulkhead connector wire entry view

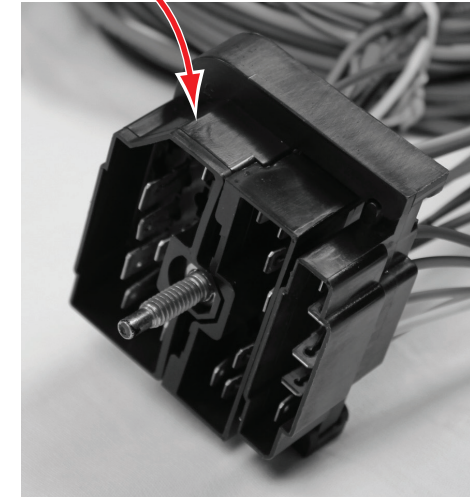











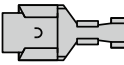

**Note:** Obtain the fuel pump wire "X" as found on pages 6 and 19 of this instruction set, plug it into the location shown at the left, then assemble the 510841 engine, 510842 front light, and 510843 rear body harnesses, and plug that assembly onto the firewall bulkhead connector. Route the other end to your fuel pump or fuel pump relay area, cut off the female terminal, and attach it to the pump or relay.

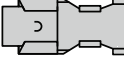
**1971-80 IH Scout**  
**510838**  
*Classic Update Series*  
92973231 Rev 1.0 10/14/2024

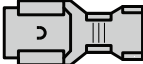
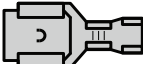
## 510842 Front Light installation instructions:

Below are the supplied terminals, connector bodies, pigtail assemblies, and assorted components included in the 510842 Front light Harness and Loose Piece bags. These will be used to complete your Front light Harness connections as shown on page 25, and are referened by the letters and descriptions below.

- |   |   |   |   |  |   |
|---|---|---|---|--|---|
| A |    | (connector, 56 series 2-way male with lock, 4 pcs)      | L |   | (Front Side Marker Extensions, 2 pcs)       |
| B |    | (connector, 56 series 2-way female with lock, 4 pcs)    | M |   | (Front Headlight Connection Pigtail, 2 pcs) |
| C |    | (terminal, 56 series single female, 14 pcs)             | N |   | (Fan Relay Trigger Wire, 1 pc)              |
| D |    | (terminal, 56 series double female, 7 pcs)              | P |  | (Fog Lamp Feed Wire Jumper, 1 pc )          |
| E |  | (terminal, 59 series double female, 4 pcs)              |   |  |   |
| F |  | (terminal, 59 series single female, 4 pcs)              |   |  |   |
| G |  | (connector, 56 series 1-way female without lock, 3 pcs) |   |  |   |
| H |  | (connector, 56 series 1-way female with lock, 1 pc)     |   |  |   |
| J |  | (connector, 56 series 1-way male with lock, 1 pc)       |   |  |   |
| K |  | (terminal, 56 series single male, 7 pcs)                |   |  |   |



www.americanautowire.com 856-933-0801

**1971-80 IH Scout**  
**510838**

*Classic Update Series*

92973231 Rev 1.0 10/14/2024



# 510842 Front Light installation instructions:



www.americanautowire.com 856-933-0801

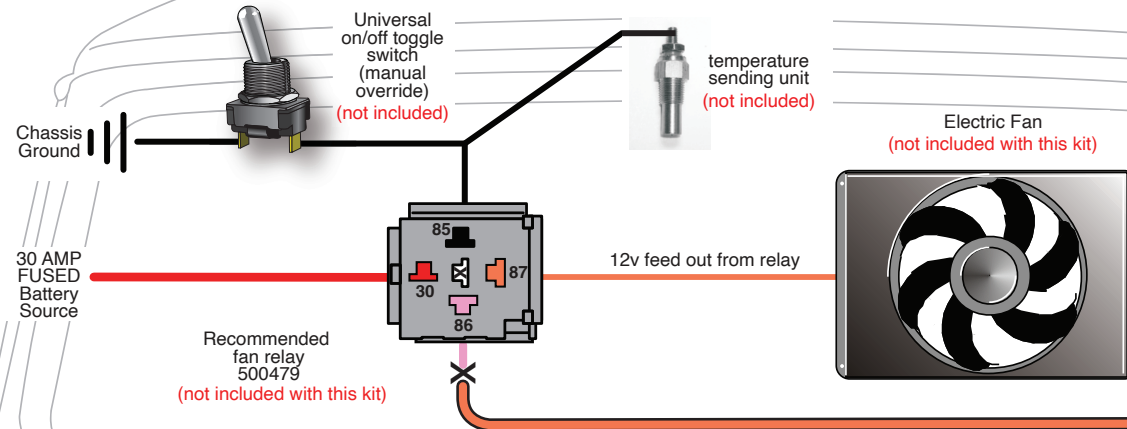

apply die-electric grease to the back side of the connector after all terminals/wires are installed in the connector. (see page 30 for details)

apply silicone sealant to the face of the connector after installing the terminals/wires. (see page 30 for details)

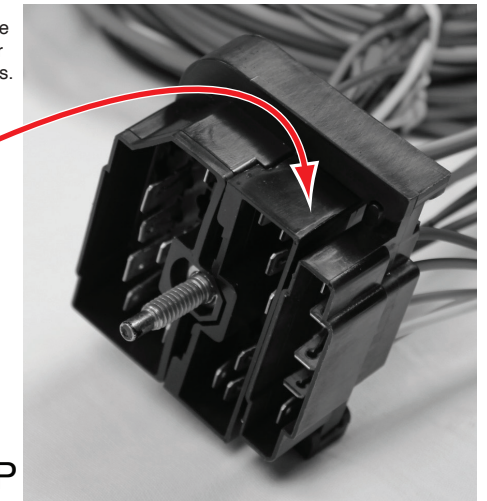

**Note 1:** If your truck has electric fans, obtain the electric fan wire "N" as found on page 24 of this instruction set and plug it into the location shown at the right. (No terminals or connectors have been provided to make these connections)

**Note 2:** If your truck has fog or driving lamps, obtain the fog lamp wire "P" as found on page 24 of this instruction set and plug it into the location shown at the right.

Next, assemble the 510841 engine, 510842 front light, and 510843 rear body harnesses, and plug that assembly onto the firewall bulkhead connector. Route all of the front light harness wiring to their locations as shown at the right and below, and using the terminals and connectors provided, make the connections.

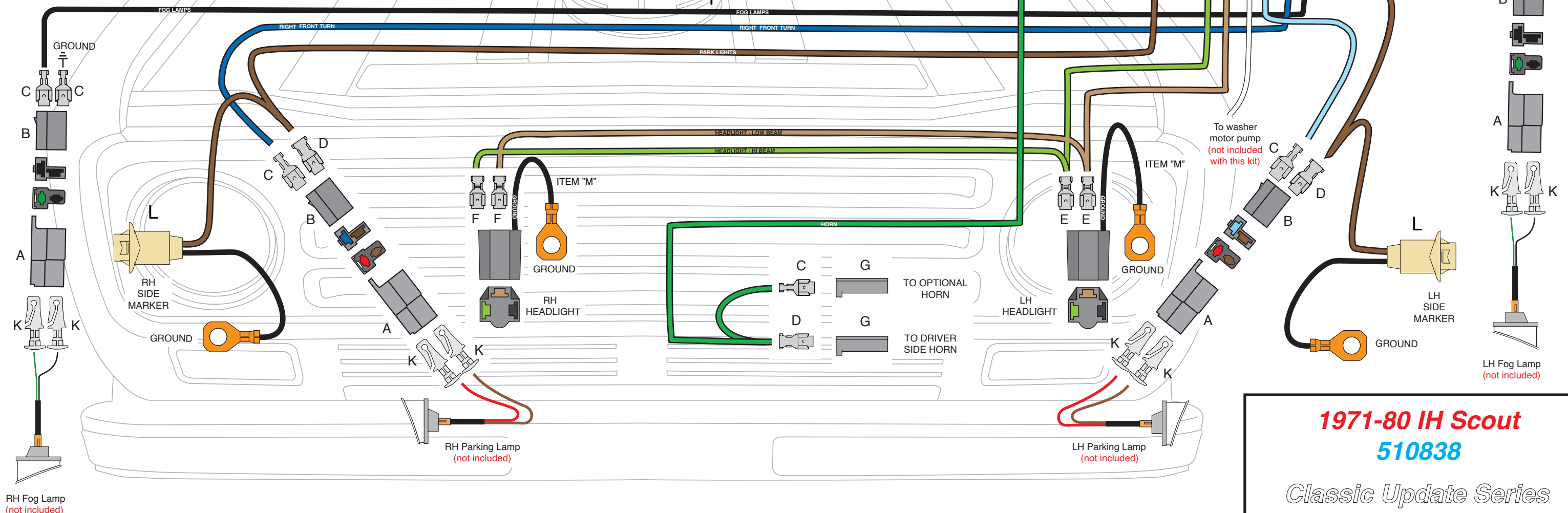

**1971-80 IH Scout**  
**510838**

Classic Update Series

92973231 Rev 1.0 10/14/2024

# 510843 Rear Body harness installation instructions:

Below are the supplied terminals, connector bodies, pigtail assemblies, and assorted components included in the 510843 Rear Body Harness and Loose Piece bags. These will be used to complete your Rear Body Harness exterior and interior connections as shown on pages 27 through 29, and are referenced by the letters and descriptions below.

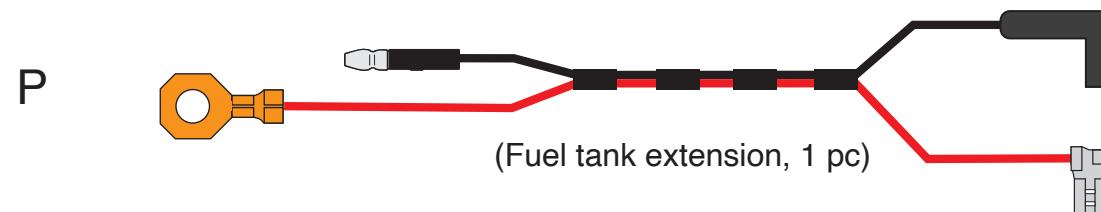
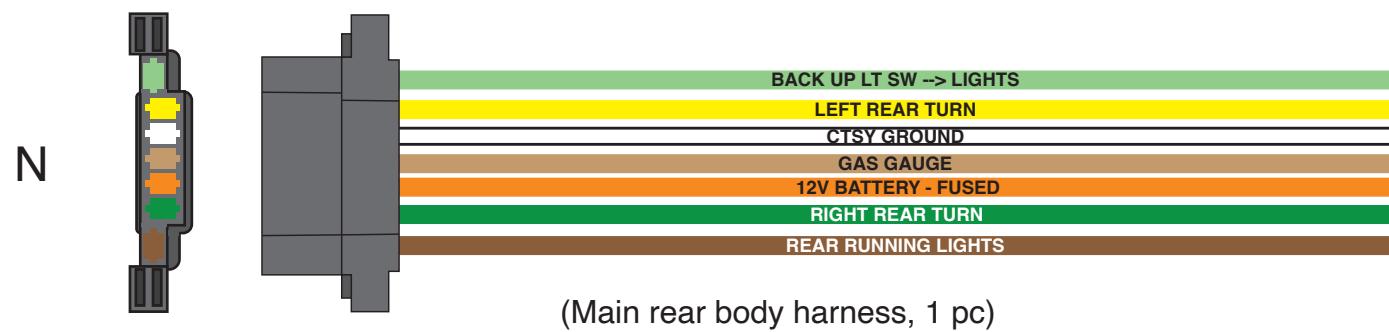
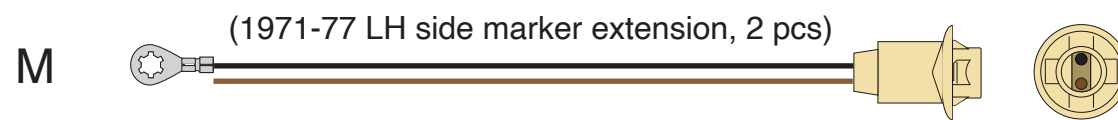
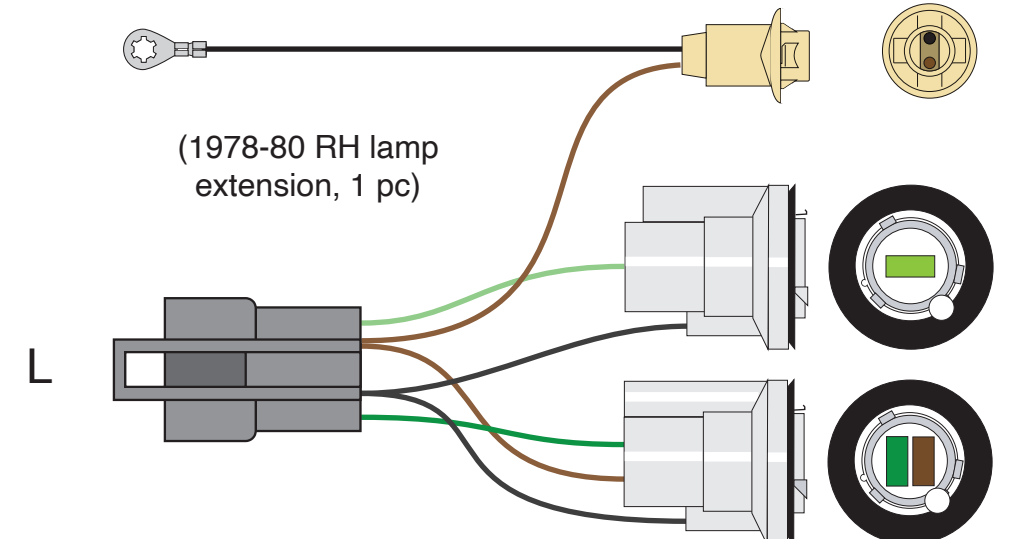
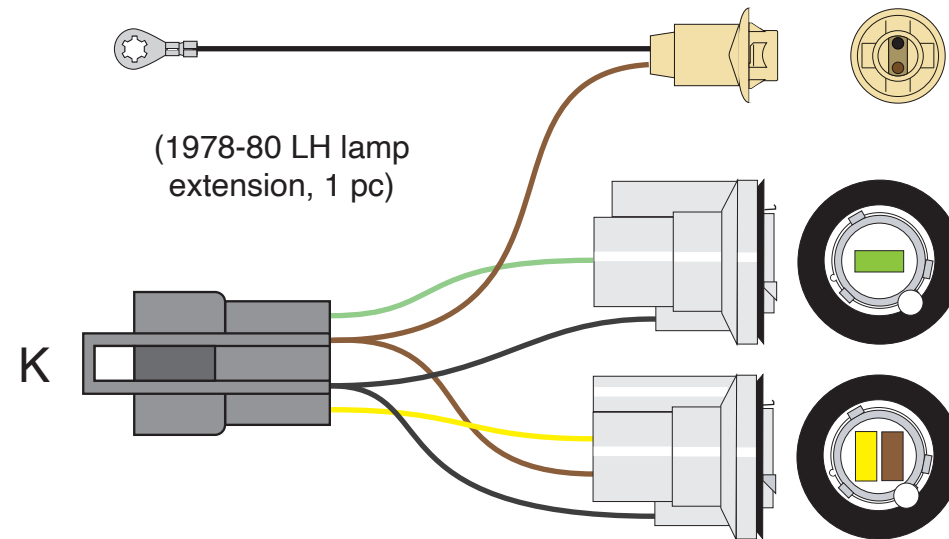
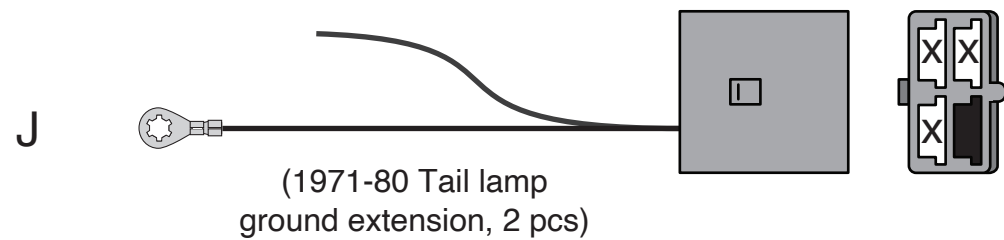
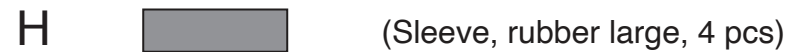
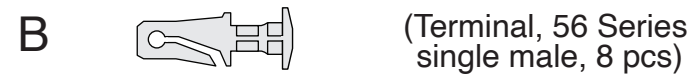
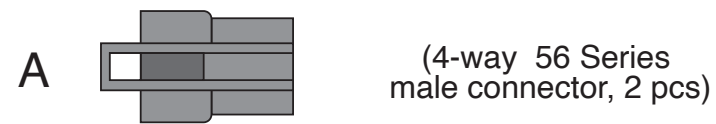

**1971-80 IH Scout**  
**510838**  
*Classic Update Series*  
92973231 Rev 1.0 10/14/2024

# 510843 Rear Body harness installation instructions:

## 1971-77 rear body harness installation instructions:

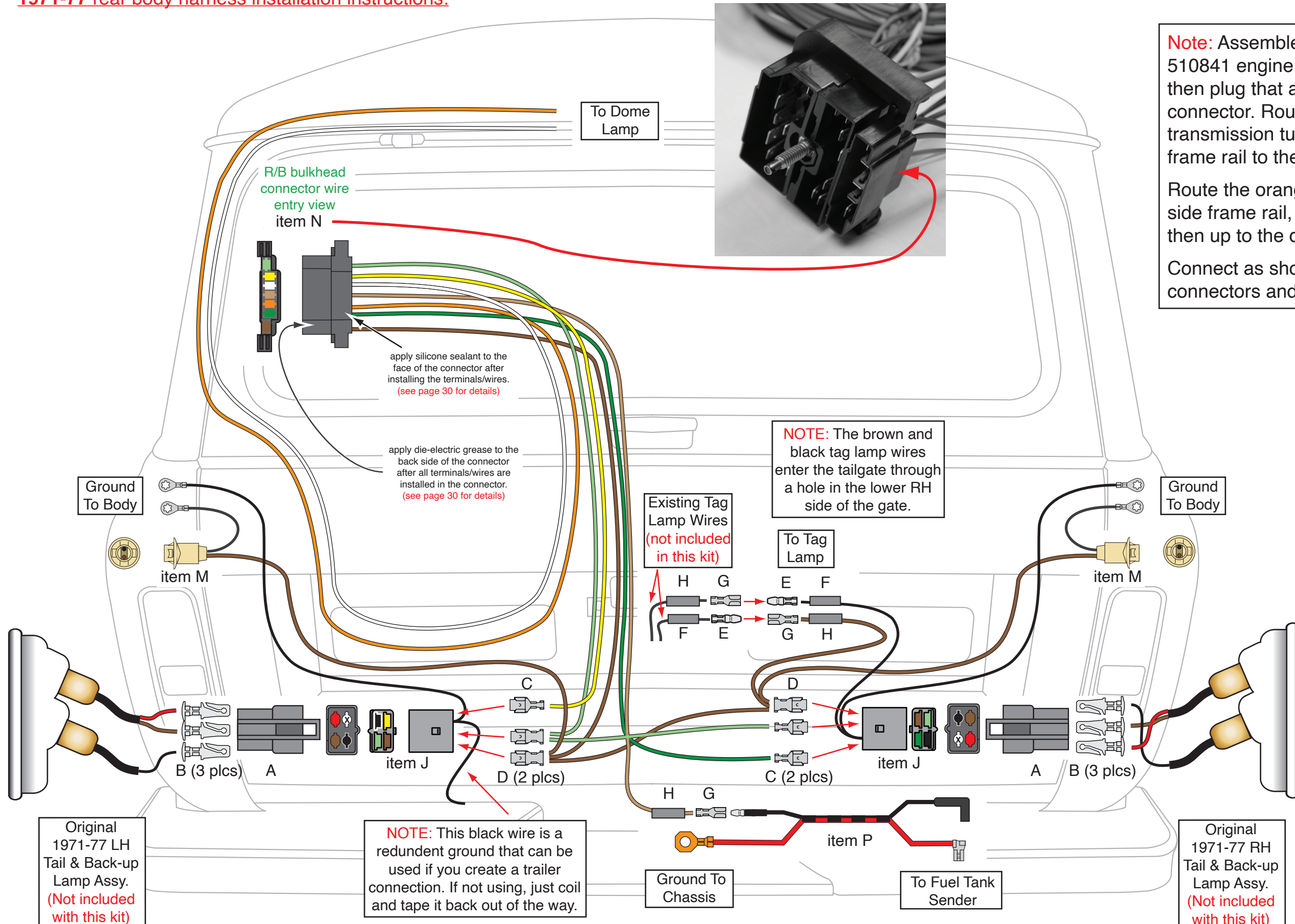

**Note:** Assemble "N" (the 510843 rear body), the 510841 engine and 510842 front light harnesses, then plug that assembly onto the firewall bulkhead connector. Route item "P" harness over to the transmission tunnel area and down the driver side frame rail to the back of the truck.

Route the orange and white wires down the driver side frame rail, up through the floor into the cabin, then up to the dome lamp assembly.

Connect as shown below using the terminals, connectors and pigtails from page 26.



www.americanautowire.com 856-933-0801

**1971-80 IH Scout  
510838**

*Classic Update Series*

92973231 Rev 1.0 10/14/2024

# 510843 Rear Body harness installation instructions:

## 1978-80 rear body harness installation instructions:

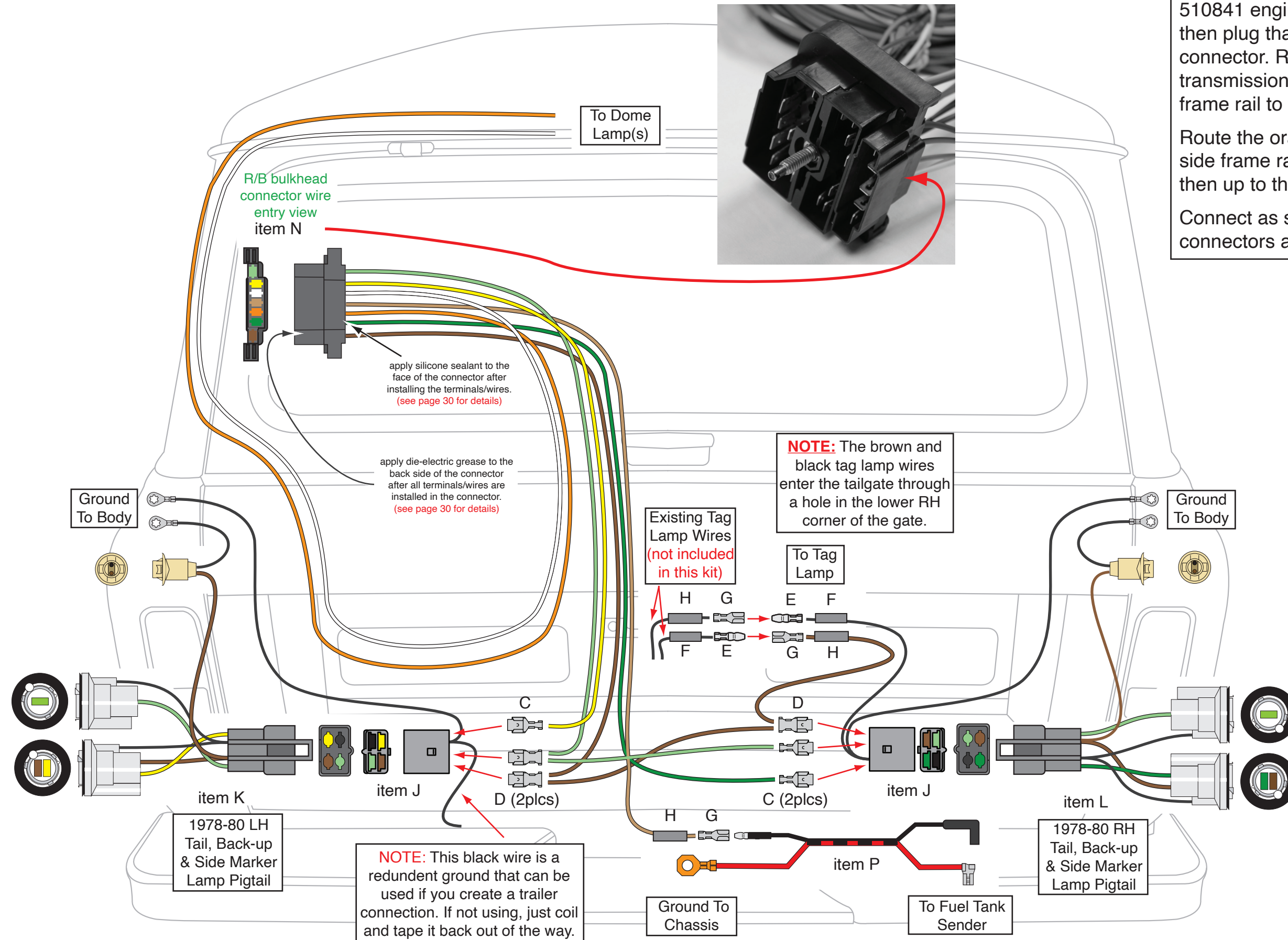

**Note:** Assemble "N" (the 510843 rear body), the 510841 engine and 510842 front light harnesses, then plug that assembly onto the firewall bulkhead connector. Route item "P" harness over to the transmission tunnel area and down the driver side frame rail to the back of the truck.

Route the orange and white wires down the driver side frame rail, up through the floor into the cabin, then up to the dome lamp assembly.

Connect as shown below using the terminals, connectors and pigtails from page 26.



www.americanautowire.com 856-933-0801

**1971-80 IH Scout**  
**510838**

*Classic Update Series*

92973231 Rev 1.0 10/14/2024

# 510843 Rear Body harness installation instructions:

## TRAVELER rear body harness installation instructions:

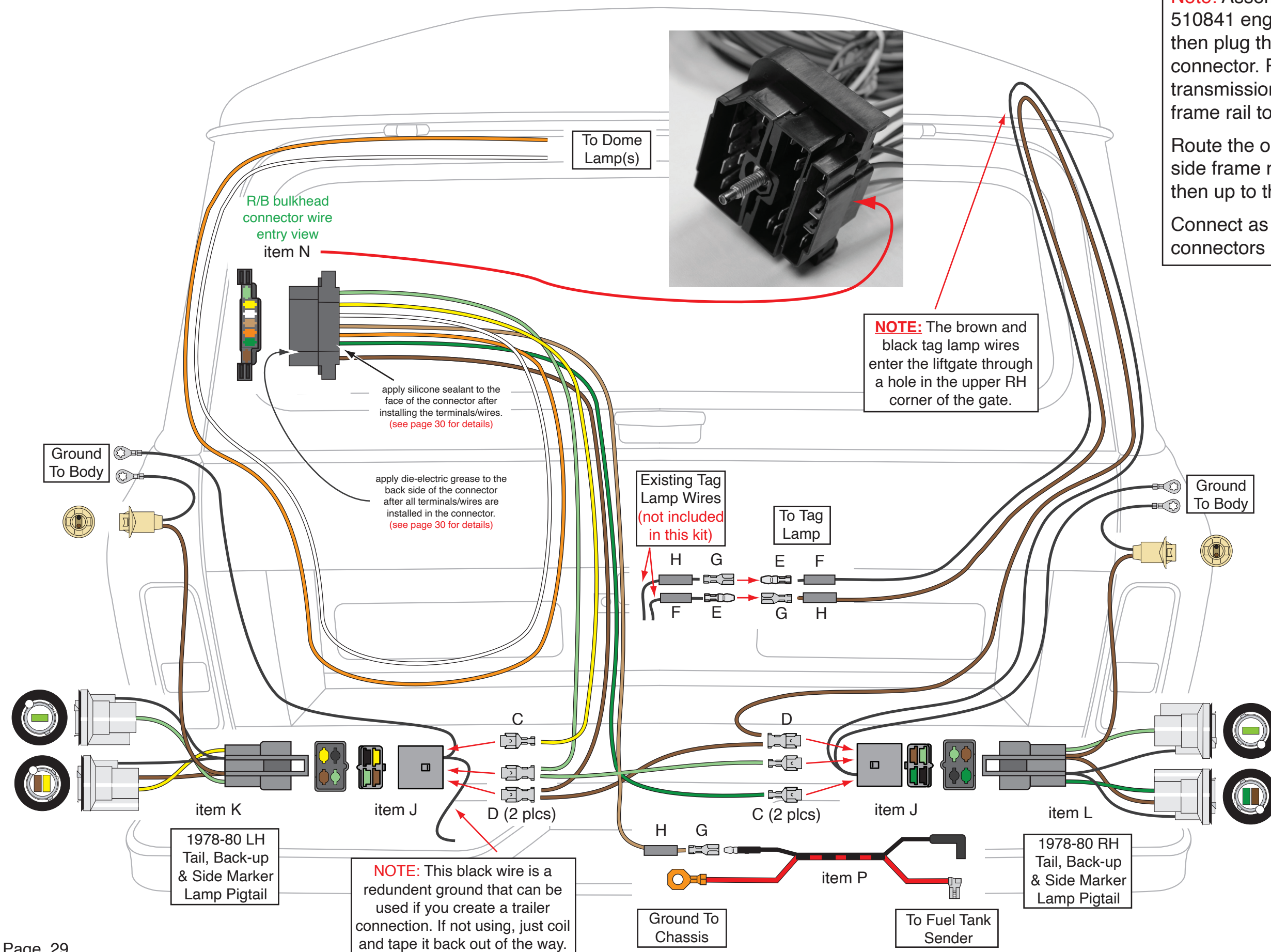

**Note:** Assemble "N" (the 510843 rear body), the 510841 engine and 510842 front light harnesses, then plug that assembly onto the firewall bulkhead connector. Route item "P" harness over to the transmission tunnel area and down the driver side frame rail to the back of the truck.

Route the orange and white wires down the driver side frame rail, up through the floor into the cabin, then up to the dome lamp assembly.

Connect as shown below using the terminals, connectors and pigtails from page 26.

**NOTE:** The brown and black tag lamp wires enter the liftgate through a hole in the upper RH corner of the gate.

apply silicone sealant to the face of the connector after installing the terminals/wires. (see page 30 for details)

apply die-electric grease to the back side of the connector after all terminals/wires are installed in the connector. (see page 30 for details)

**NOTE:** This black wire is a redundant ground that can be used if you create a trailer connection. If not using, just coil and tape it back out of the way.



**1971-80 IH Scout**  
**510838**  
*Classic Update Series*  
 92973231 Rev 1.0 10/14/2024

## 510838 finishing detail installation instructions:

Making your firewall electrical connection corrosion and weather resistant:

engine harness  
20-way connector

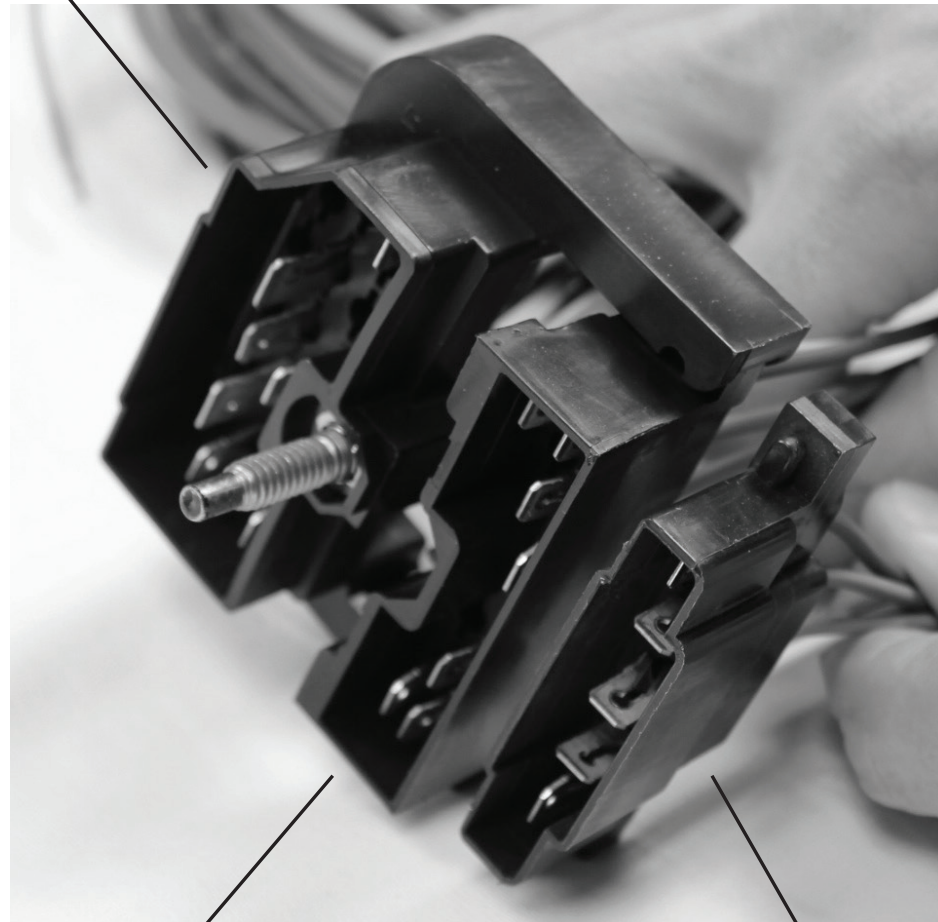

assembly, ready to bolt  
onto firewall bulkhead

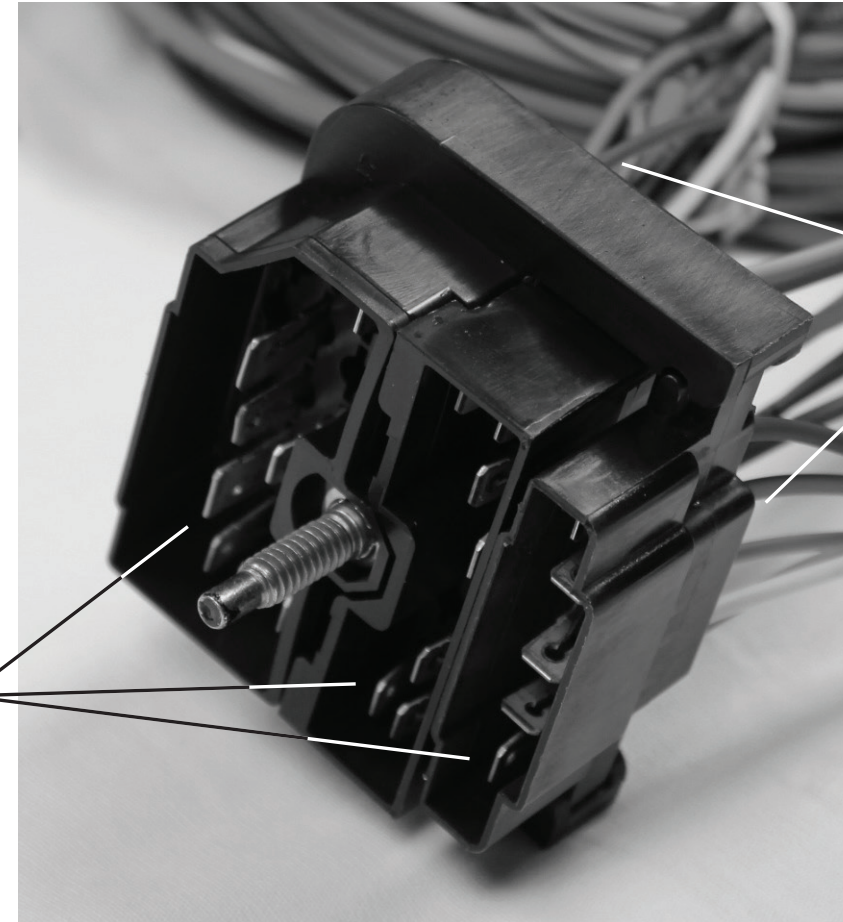

apply dielectric  
grease to the  
terminals after  
all wires are installed

apply silicone sealant,  
to back side of connectors,  
after installing terminals

front light  
10-way connector

rear body  
7-way connector

**NOTE:** We recommend the following once you have completed the installation of your underhood engine, forward lamp and rear body connections:

1. Remove the engine, front light and rear body connector assembly from the firewall and apply dielectric grease to the terminals as shown above. This will help with continuity and also prevent corrosion to any of the terminals.
2. Re-attach the engine, front light and rear body connector assembly to the firewall and apply silicone sealer to the back of the connectors as shown above. This will help seal the connector and keep water and moisture from going through to the inside of the vehicle via the bulkhead assembly.



www.americanautowire.com 856-933-0801

**1971-80 IH Scout**  
**510838**

*Classic Update Series*

92973231 Rev 1.0 10/14/2024

A  (1)  
 (144.0" 6 Gauge charge wire)

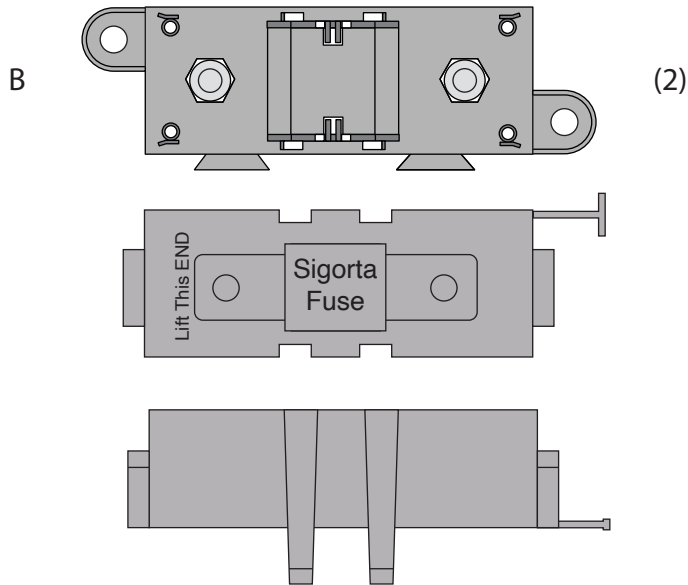

1. On this page, you will find the wire, fuse bodies, fuses, boot, ring terminals, and shrink tubing (items A through K) that are necessary to connect your alternator and main power feed for your new AAW wiring kit. Please be sure that all of the necessary components are present before starting this portion of your installation. If anything is missing, stop what you are doing and contact AAW at the number listed below right away.

2. On page 2, you will find directions for building the 2 Megafuse assemblies (items B,C and D) into one unit.

3. On page 3, you will find an overall concept of how to connect the Megafuse assemblies to your starter solenoid, alternator and main power feed of your new wiring system.

4. On page 4, you will find tips on building your charging circuit wires and assembling them and the main panel power feed wire to the Megafuse assemblies.

(Megafuse body, cover and two M8 x 1.25 nuts / lock washers)

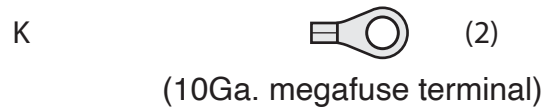
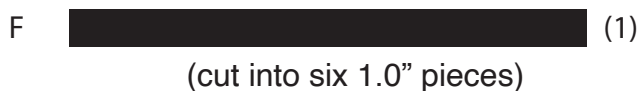
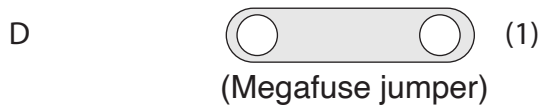
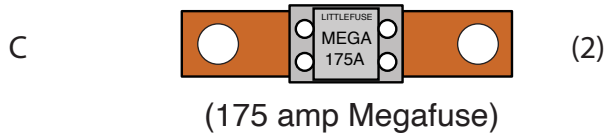

www.americanautowire.com 856-933-0801

PART #

510476

Z

DESCRIPTION:

Alternator and Main Power  
 Connection Kit  
 Various Applications

92972153 instruction sheet rev 0.1 6/24/2019

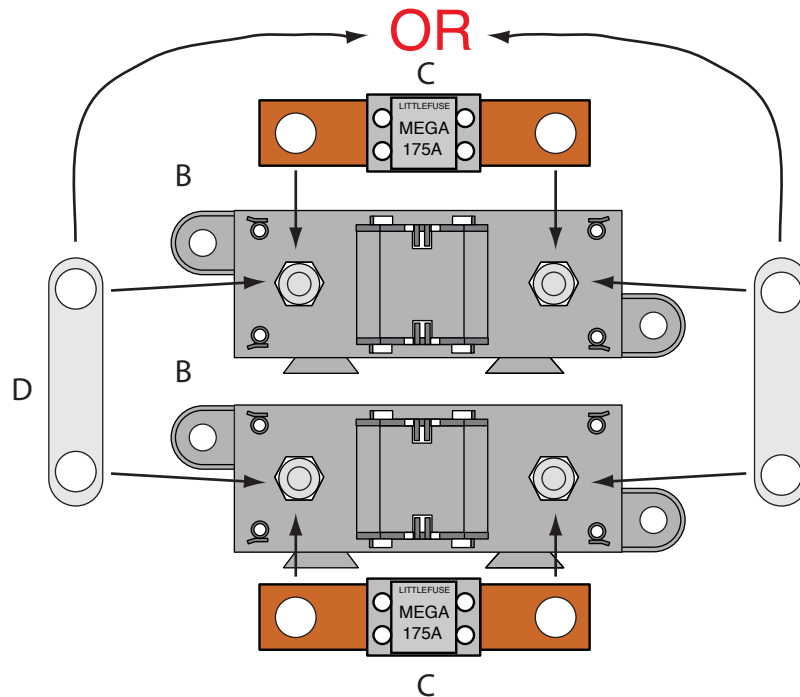

## Assembling the (2) Megafuse assemblies

**NOTE:** Find a suitable place, as close to the battery power source as possible, under the hood of your vehicle to mount the completed Megafuse assemblies. Keep in mind that you have 12 feet of 6Ga. charging wire, and that the main power feed coming from your panel or bulkhead connection must also be able to reach the assembly.

1. Take the two Megafuse bodies and covers (items B) and snap them together. Remove the 4 nuts and lock washers from the studs on the fuse body assemblies.
2. Install the Megafuse jumper (item D above) over two of the studs on the Megafuse bodies. It is very important that the jumper **MUST BE** assembled on the side that is going to connect to your main power connection (starter solenoid or battery feed).
3. Notch top cover to clear jumper D as shown at right.
4. Snap one 175amp fuse (items C) onto the studs of each of the two Megafuse bodies (items B), over the jumper, then loosely re-attach the 4 nuts and lock washers back onto the assembled Megafuses. The fuse assemblies are ready to install into your vehicle.

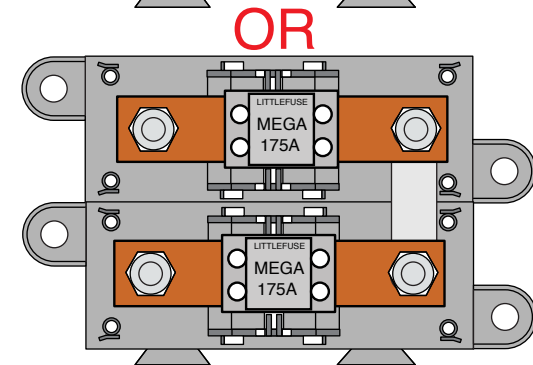
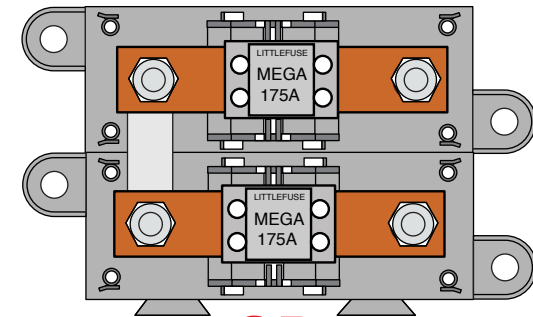

## Assembled Megafuses

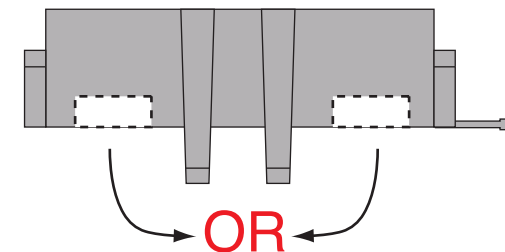

## Notched Cover

PART #

**510476**

**Z**

DESCRIPTION:

Alternator and Main Power  
Connection Kit  
Various Applications

92972153 instruction sheet rev 0.1 6/24/2019



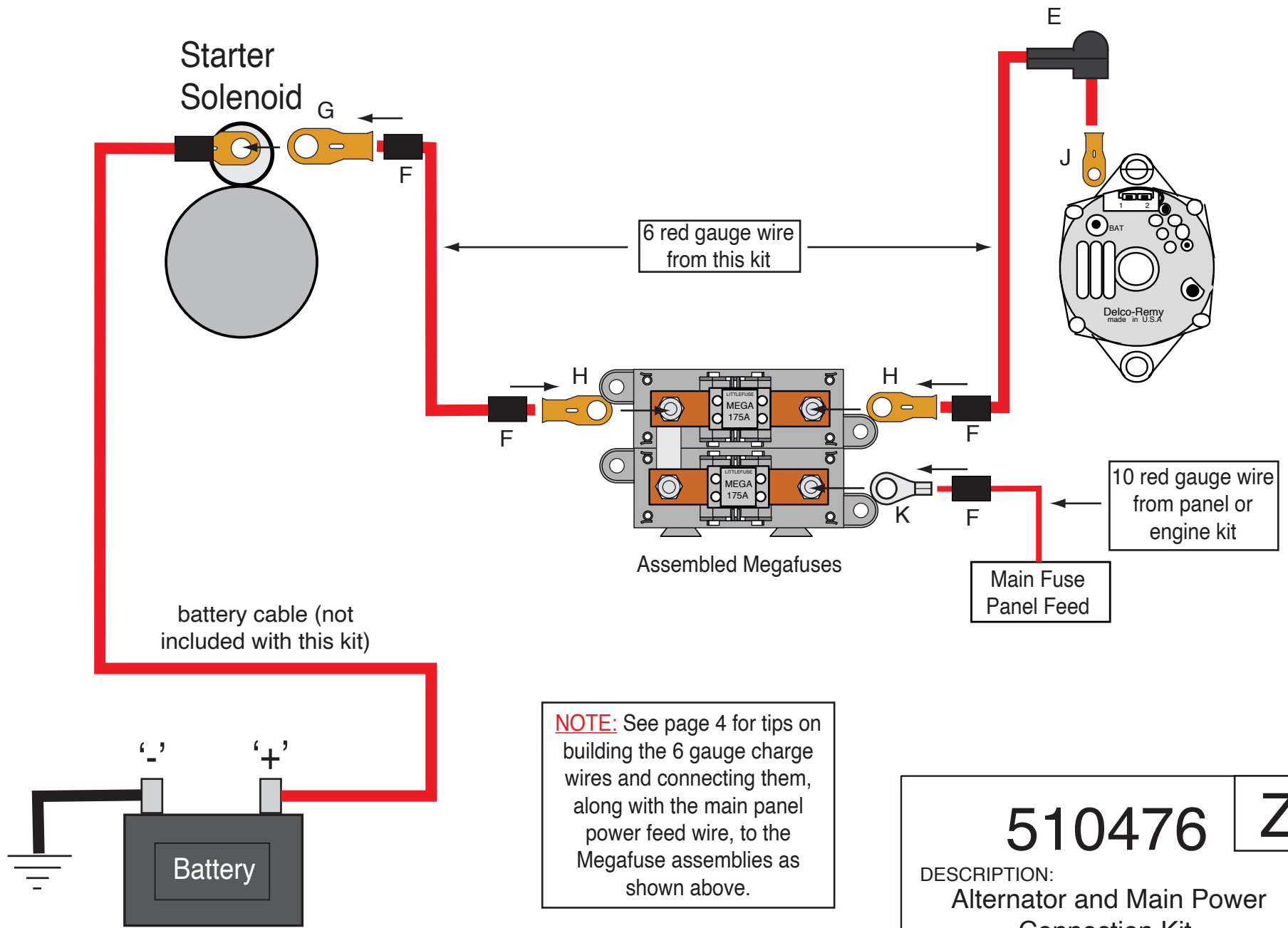

**NOTE:** See page 4 for tips on building the 6 gauge charge wires and connecting them, along with the main panel power feed wire, to the Megafuse assemblies as shown above.

<h1>510476</h1>	<b>Z</b>
<p>DESCRIPTION:  <b>Alternator and Main Power Connection Kit</b>  <b>Various Applications</b></p>	
<p>92972153 instruction sheet rev 0.1 6/24/2019</p>	

## **Building the 6Ga. charge wires and connecting them and the main panel power feed wire to the Megafuse assemblies:**

**NOTE:** Make sure that your battery is disconnected! You will need to install the preassembled Megafuses from page 2 in your vehicle to start this part of the installation.

1. Pre-cut item F shrink tubing into (6) 1.00" - 1.25" pieces.
2. Take the 12-foot piece of 6Ga. red wire from this kit and route it from your starter (or other battery feed) over to the area where you have mounted your Megafuse and cut it to length. Strip the insulation on each end back 1/2". Install 2 pieces of shrink tubing F onto the wire. At the starter end, crimp and solder (1) of terminal G onto the wire. At the Megafuse end, crimp and solder (1) of terminal H onto the wire. Slide the shrink tubing over the terminals and heat it up to shrink it down.
3. Take the remaining portion of the 12-foot piece of 6Ga. red wire from this kit and route it from your alternator over to the area where you have mounted your Megafuse and cut it to length. Strip the insulation on each end back 1/2". Install 1 piece of shrink tubing F onto the wire. At the alternator end, slip on boot E as shown on page 3, then crimp and solder (1) of terminal J onto the wire. At the Megafuse end, crimp and solder (1) of terminal H onto the wire. Slide the shrink tubing over terminal H and heat it up to shrink it down.
4. Take the 10Ga. red main power feed wire from your engine or panel sub-kit and route it over to the area where you have mounted your Megafuse and cut it to length. Strip the insulation back 3/8". Install 1 piece of shrink tubing F onto the wire, then crimp and solder (1) of terminal K onto the wire.
5. Remove the 4 loosely tightened nuts and lock washers from the assembled Megafuses, then using the drawing on page 3 as a guide, install your pre-assembled wires from steps 2-4 above. Re-install the 4 nuts and lock washers onto the assembled Megafuses and tighten them down. This part of your installation is now complete.

**510476**

**Z**

DESCRIPTION:

**Alternator and Main Power  
Connection Kit  
Various Applications**

92972153 instruction sheet rev 0.1 6/24/2019

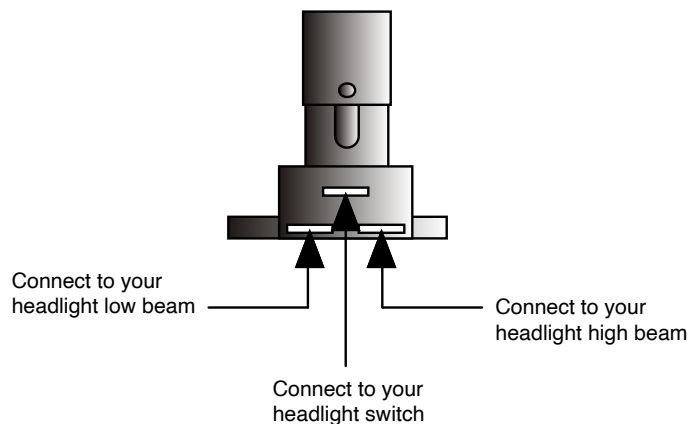

Connect the Dimmer Switch wires as shown above.

1. The top center terminal of the Dimmer Switch is connected to the Headlight switch.
2. The terminal on the right side is connected to your headlight high beam terminal.
3. The terminal on the left side is connected to your headlight low beam terminal.



www.americanautowire.com 856-933-0801

PART #

**500042**

DESCRIPTION:

**DIMMER SWITCH**

92964573 Rev 3.1 12/5/2014

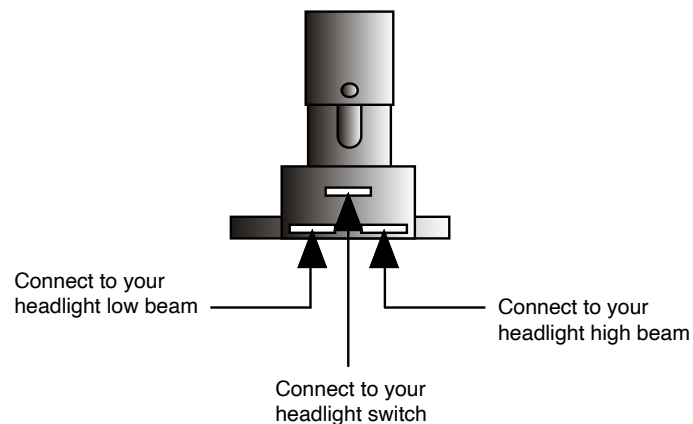

Connect the Dimmer Switch wires as shown above.

1. The top center terminal of the Dimmer Switch is connected to the Headlight switch.
2. The terminal on the right side is connected to your headlight high beam terminal.
3. The terminal on the left side is connected to your headlight low beam terminal.



www.americanautowire.com 856-933-0801

PART #

**500042**

DESCRIPTION:

**DIMMER SWITCH**

92964573 Rev 3.1 12/5/2014